



CITY OF
FOLSOM
DISTINCTIVE BY NATURE

HISTORIC DISTRICT COMMISSION AGENDA

April 21, 2021

CITY COUNCIL CHAMBERS

5:00 p.m.

50 Natoma Street

Folsom, California 95630

Pursuant to Governor Newsom's Executive Order N-29-20, members of the Folsom Historic District Commission and staff may participate in this meeting via teleconference.

Due to the coronavirus (COVID-19) public health emergency, the City of Folsom is allowing remote public input during Commission meetings. Members of the public are encouraged to participate by e-mailing comments to kmullett@folsom.ca.us. E-mailed comments must be received no later than thirty minutes before the meeting and will be read aloud at the meeting during the agenda item. Please make your comments brief. Written comments submitted and read into the public record must adhere to the principles of the three-minute speaking time permitted for in-person public comment at Commission meetings. Members of the public wishing to participate in this meeting via teleconference may email kmullett@folsom.ca.us no later than thirty minutes before the meeting to obtain call-in information. Each meeting may have different call-in information. Verbal comments via teleconference must adhere to the principles of the three-minute speaking time permitted for in-person public comment at Historic District Commission meetings.

Members of the public may continue to participate in the meeting in person at Folsom City Hall, 50 Natoma Street, Folsom CA while maintaining appropriate social distancing.

CALL TO ORDER HISTORIC DISTRICT COMMISSION: Mark Dascallos, John Felts, Daniel West, Kathleen Cole, Mickey Ankhelyi, Kevin Duewel, Daron Bracht

Any documents produced by the City and distributed to the Historic District Commission regarding any item on this agenda will be made available at the Community Development Counter at City Hall located at 50 Natoma Street, Folsom, California and at the table to the left as you enter the Council Chambers.

PLEDGE OF ALLEGIANCE

CITIZEN COMMUNICATION: The Historic District Commission welcomes and encourages participation in City Historic District Commission meetings, and will allow up to five minutes for expression on a non-agenda item. Matters under the jurisdiction of the Commission, and not on the posted agenda, may be addressed by the general public; however, California law prohibits the Commission from taking action on any matter which is not on the posted agenda unless it is determined to be an emergency by the Commission.

MINUTES

The minutes of the April 7, 2021 meeting will be presented for approval.

NEW BUSINESS

1. PN 21-059, 908 Bidwell Street Design Review Modifications and Determination that the Project is Exempt from CEQA

A Public Meeting to consider a request from AK Developers, Inc. for approval of a Design Review application for exterior modifications to a previously approved 2,837-square-foot single-family residence with attached second unit at 908 Bidwell Street. The zoning classification for the site is R-1-M/CEN, while the General Plan land-use

designation is SFHD. The project is exempt from the California Environmental Quality Act in accordance with Section 15301 of the CEQA Guidelines. **(Project Planner: Steve Banks/Applicant: AK Developers, Inc.)**

2. PN 21-058, 813 Natoma Street Addition and Determination that the Project is Exempt from CEQA

A Public Meeting to consider a request from Eric Winokur for approval of a Design Review application for a 291-square-foot addition to an existing residence located at 813 Natoma Street. The zoning classification for the site is R-1-M/CEN, while the General Plan land-use designation is SFHD. The project is exempt from the California Environmental Quality Act in accordance with Section 15301 of the CEQA Guidelines. **(Project Planner: Josh Kinkade/Applicant: Eric Winokur)**

HISTORIC DISTRICT COMMISSION / PRINCIPAL PLANNER REPORT

The next Historic District Commission meeting is scheduled for **May 5, 2021**. Additional non-public hearing items may be added to the agenda; any such additions will be posted on the bulletin board in the foyer at City Hall at least 72 hours prior to the meeting. Persons having questions on any of these items can visit the Community Development Department during normal business hours (8:00 a.m. to 5:00 p.m.) at City Hall, 2nd Floor, 50 Natoma Street, Folsom, California, prior to the meeting. The phone number is (916) 461-6200 and fax number is (916) 355-7274.

In compliance with the Americans with Disabilities Act, if you are a disabled person and you need a disability-related modification or accommodation to participate in the meeting, please contact the Community Development Department at (916) 461-6231, (916) 355-7274 (fax) or kmullett@folsom.ca.us. Requests must be made as early as possible and at least two-full business days before the start of the meeting.

NOTICE REGARDING CHALLENGES TO DECISIONS

The appeal period for Historic District Commission Action: Pursuant to all applicable laws and regulations, including without limitation, California Government Code, Section 65009 and/or California Public Resources Code, Section 21177, if you wish to challenge in court any of the above decisions (regarding planning, zoning, and/or environmental decisions), you may be limited to raising only those issues you or someone else raised at the public hearing(s) described in this notice/agenda, or in written correspondence delivered to the City at, or prior to, this public hearing. Any appeal of a Historic District Commission action must be filed, in writing with the City Clerk's Office no later than ten (10) days from the date of the action pursuant to Resolution No. 8081.

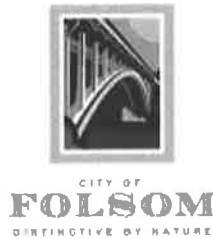

HISTORIC DISTRICT COMMISSION MINUTES
April 7, 2021
CITY COUNCIL CHAMBERS
5:00 p.m.
50 Natoma Street
Folsom, California 95630

CALL TO ORDER HISTORIC DISTRICT COMMISSION: Daniel West, Kathleen Cole, Mickey Ankhelyi, Kevin Duewel, Mark Dascallos, John Felts, Daron Bracht

ABSENT: Ankhelyi, Duewel

PLEDGE OF ALLEGIANCE

CITIZEN COMMUNICATION: None

MINUTES: The amended minutes of the March 3, 2021 meeting and the minutes of the March 17, 2021 special meeting were approved.

OLD BUSINESS

1. PN 21-017, 502 Natoma Street Remodel and Determination that the Project is Exempt from CEQA (Continued from 3/3/21 HDC Meeting)

A Public Meeting to consider a request from Adrian Blanco for approval of a Design Review application for the remodel of an existing 1,631-square-foot commercial building located at 502 Natoma Street. The zoning classification for the site is BP/NRB, while the General Plan land-use designation is CC. The project is exempt from the California Environmental Quality Act in accordance with Section 15301 of the CEQA Guidelines. **(Project Planner: Josh Kinkade/Applicant: Adrian Blanco)**

1. Bob Delp submitted a public comment letter which included recommended changes to the project and conditions of approval.

COMMISSIONER COLE MOVED TO APPROVE THE APPLICATION (PN 21-017) FOR DESIGN REVIEW FOR THE REMODELING OF AN EXISTING 1,631-SQUARE-FOOT COMMERCIAL BUILDING LOCATED AT 502 NATOMA STREET AND ASSOCIATED SITE WORK AS ILLUSTRATED ON ATTACHMENT 5 FOR THE 502 NATOMA STREET REMODEL PROJECT, SUBJECT TO THE FINDINGS INCLUDED IN THIS REPORT (FINDINGS A-H) AND ATTACHED CONDITIONS OF APPROVAL NOS. 1-8 WITH THE FOLLOWING REVISION TO CONDITION NO. 8:

"8. The project approval granted under this staff report shall remain in effect for one year from final date of approval (~~May 7, 2022~~ **April 7, 2022**). Failure to obtain the relevant building, demolition, or other permits within this time period, without the subsequent extension of this approval, shall result in the termination of this approval."

COMMISSIONER WEST SECONDED THE MOTION WHICH CARRIED THE FOLLOWING VOTE:

AYES: WEST, COLE, DASCALLOS, BRACHT
NOES: NONE
RECUSED: FELTS
ABSENT: ANKHELYI, DUEWEL

NEW BUSINESS

2. PN 21-034, 300 Reading Street Sign Permit and Determination that the Project is Exempt from CEQA

A Public Meeting to consider a request from William Henderson for approval of a Sign Permit application for 20-square-foot wall sign on the frontage of the Folsom City Ink business located at 300 Reading Street. The zoning classification for the site is C-2 PD/SUT, while the General Plan land-use designation is HF. The project is exempt from the California Environmental Quality Act in accordance with Section 15301 of the CEQA Guidelines. **(Project Planner: Josh Kinkade/Applicant: William Henderson)**

COMMISSIONER COLE MOVED TO APPROVE THE 300 READING STREET SIGN PERMIT (PN 21-034), SUBJECT TO THE FINDINGS INCLUDED IN THIS REPORT (FINDINGS A-J) AND ATTACHED CONDITIONS OF APPROVAL NOS. 1-7 WITH THE FOLLOWING REVISION TO CONDITION NO. 1:

"1. This Sign Permit is approved for the Folsom City Ink business at 300 Reading Street, which shall substantially conform to the exhibits included in the April 14, 2021 staff report in Attachment 5. **The sign background will be beige to the satisfaction of the Community Development Department.**"

COMMISSIONER DASCALLOS SECONDED THE MOTION WHICH CARRIED THE FOLLOWING VOTE:

AYES: WEST, COLE, DASCALLOS, FELTS, BRACHT
NOES: NONE
RECUSED: NONE
ABSENT: ANKHELYI, DUEWEL

PRINCIPAL PLANNER REPORT

The next regularly scheduled meeting of the Historic District Commission will be held April 21, 2021.

RESPECTFULLY SUBMITTED,

Kelly Mullett, ADMINISTRATIVE ASSISTANT

APPROVED:

Daron Bracht, CHAIR



CITY OF
FOLSOM
DISTINCTIVE BY NATURE

AGENDA ITEM NO. 1
Type: Public Meeting
Date: April 21, 2021

Historic District Commission Staff Report

50 Natoma Street, Council Chambers
Folsom, CA 95630

Project: 908 Bidwell Street Design Review Modifications
File #: PN 21-059
Request: Design Review
Location: 908 Bidwell Street
APN: 070-0201-010
Staff Contact: Steve Banks, Principal Planner, 916-461-6207
sbanks@folsom.ca.us

Property Owner

Name: Brian Martell
Address: 222 Wellfleet Circle
Folsom, CA 95630

Applicant

Name: AK Developers, Inc.
Address: 705 East Bidwell Street, Suite 2312
Folsom, CA 95630

Recommendation: Conduct a public meeting and upon conclusion recommend approval of Design Review for exterior modifications to a previously approved 2,837-square-foot single-family residence with attached second unit as illustrated on Attachments 7 through 9 for the 908 Bidwell Street Design Review Modifications project (PN 21-059) subject to the findings (Findings A-I) and conditions of approval (Conditions 1-22) attached to this report.

Project Summary: The proposed project involves a request for approval of Design Review for exterior modifications to a previously approved 2,837-square-foot single-family residence with attached second unit located at 908 Bidwell Street with the intent of creating a more historically appropriate appearance. Proposed architectural modifications include changes to the number, location, and size of various windows, the addition of wood trim around all windows and doors, relocation of the front door on the primary residence, relocation of the front door and staircase on the second unit, roof modifications to a portion of the main residence, adding a cantilever element and belly-band to the second unit, altering the design of the garage door, and changing the color scheme of the primary residence and second unit.



CITY OF
FOLSOM
DISTINCTIVE BY NATURE

Table of Contents:

- 1 - Description/Analysis
- 2 - Background
- 3 - Conditions of Approval
- 4 - Vicinity Map
- 5 - Previously Approved Site Plan, dated September 17, 2018
- 6 - Previously Approved Building Elevations and Floor Plan, dated September 17, 2018
- 7 - Proposed Site Plan, dated June 19, 2020
- 8 - Proposed Building Elevations and Floor Plan, dated December 22, 2020,
September 17, 2018, November 16, 2020 and January 29, 2021
- 9 - Color and Materials Board
- 10 - Project Narrative, dated March 25, 2021
- 11 - 908 Bidwell Street Design Review, Variances, and Demolition Historic District
Commission Staff Report, dated November 14, 2018
- 12 - Minutes from November 14, 2018 Historic District Commission Meeting
- 13 - Site Photographs

Submitted,

A handwritten signature in blue ink, appearing to read "Pam Johns", with a long horizontal flourish extending to the right.

PAM JOHNS
Community Development Director

ATTACHMENT 1 DESCRIPTION/ANALYSIS

APPLICANT'S PROPOSAL

The applicant, AK Developers, Inc., is requesting Design Review approval for a number of exterior modifications to a previously approved 2,837-square-foot single-family residence with attached second unit located at 908 Bidwell Street. Proposed architectural modifications include changes to the number, location, and size of various windows, the addition of wood trim around all windows and doors, relocation of the front door on the primary residence, relocation of the front door and staircase on the second unit, roof modifications to a portion of the main residence, adding a cantilever element to the second unit, adding a bellyband to the second unit, altering the design of the garage door, and changing the color scheme of the primary residence and second unit. As mentioned previously within this report, the applicant's stated intent with the proposed design modifications is to create a more historically appropriate appearance that better reflects a craftsman-style design. In addition, the applicant's intent with the proposed design modifications is to address conditions of approval previously placed on the project by the Historic District Commission.

POLICY/RULE

Section 17.52.300 of the Folsom Municipal Code (FMC) states that the Historic District Commission shall have final authority relating to the design and architecture of all exterior renovations, remodeling, modification, addition or demolition of existing structures within the Historic District. Section 17.52.330 states that, in reviewing projects, the Commission shall consider the following criteria:

- a) Project compliance with the General Plan and any applicable zoning ordinances;
- b) Conformance with any city-wide design guidelines and historic district design and development guidelines adopted by the city council;
- c) Conformance with any project-specific design standards approved through the planned development permit process or similar review process; and
- d) Compatibility of building materials, textures and colors with surrounding development and consistency with the general design theme of the neighborhood.

ANALYSIS

General Plan and Zoning Consistency

The General Plan land use designation for the project site is SFHD (Single Family High Density) and the zoning designation for the project site is CEN/R-1-M (Central Subarea of the Historic Residential Primary Area/Single-Family Dwelling, Small Lot District). The Folsom Municipal Code (FMC, Section 17.52.540) indicates that single-family dwellings are a permitted use within the Central Subarea of the Historic Residential Primary Area. In addition, the Folsom Municipal Code (FMC, Section 17.015.010(c)) states that second units are allowed on parcels zoned for single unit residential uses. FMC section 17.52.490 requires that ADUs in the Historic District shall comply with the standards in FMC Chapter 17.105. The table on the following page outlines the development standards that are applicable to the proposed project:

Development Standards Table		
	Required	Existing/Proposed
Minimum Lot Size	6,000 S.F.	5,500 S.F.
Minimum Lot Width	50 Feet	50 Feet
Required Front Yard Setback	20 Feet	20 Feet
Required Rear Yard Setback	20 Feet	3 Feet
Required Side Yard Setbacks	5 Feet each side	3 Feet and 7 Feet 9 Inches
Minimum Distance Between Structures	10 Feet	>10 Feet
Maximum Building Height	35 Feet	28 Feet
Minimum Parking Required	2 Parking Spaces	2 Parking Spaces
Minimum Pervious Surface	40%	45%

As shown in the table above, the proposed project meets some of the applicable development standards including minimum lot width, required front yard setback, required right side yard setback, distance between structures, maximum building height, minimum parking, and minimum pervious surface. However, the proposed project does not meet the applicable development standards relative to minimum lot size, required rear yard setback, and required left side yard setback. The Historic District Commission previously granted approval of Variances for deviation from the development standards described above and staff has determined that the proposed project is in substantial compliance with the approved Variances.

During plan review for building code compliance for initial building permit request at 908 Bidwell, City Staff identified several challenges with the proposed plans relative to the non-conforming setbacks. As a result, staff approved minor modifications to those non-conforming walls to be more conforming and mistakenly approved more significant demolition than what was originally granted by the Historic District Commission (and City Council on appeal). During previous discussions with the Historic District Commission and City Council, City Staff explained the plan check challenges, staff

approved modifications, and approved demolition error. Staff also identified actions to improve reviews, as well as checks and balances in the process moving forward. The focus of this request is on new exterior design modifications proposed by the applicant. Some of the modifications have been constructed before receiving necessary approvals. Historic District Commission review and approval is required to allow those modifications prior to any final sign off or certificate of occupancy at 908 Bidwell.

Architecture/Design

As described previously within this report, the proposed project includes a number of design changes to the previously approved 2,837-square-foot residence and second unit with the purpose of reinforcing the Craftsman-style design theme. Below is a detailed description of each of the proposed design modifications:

Window and Door Alterations

- East Elevation: Eliminate the double doors located on the main residence and spread out the three picture windows evenly. Eliminate the two square picture windows over the gable section of the main residence and replace these windows to two vertical casement windows and a horizontal sliding window. Add a front entry door on the right side of the primary residence.
- West Elevation: Add a new vertical window on the second story of the second unit. Change the window located on the left side of the second story from a horizontal window to a vertical window.
- North Elevation: Add two vertical windows to the rear of the main residence Relocate a small horizontal window from the left side on the second story of the second unit to the right side on the second story. Eliminate one ground level door and two ground level windows on the rear of the second unit. Add an exterior staircase and second floor entry door to the rear of the second unit.
- South Elevation: Eliminate the French doors and one of the horizontal picture windows and replace with three small picture windows on the main residence.

Window and Door Trim

- Add detailed wood window trim around all door and windows including 1x4 trim on the vertical sides, 1x6 trim on the top and bottom of the windows and doors, and 1x2 apron on the bottom of the windows.

Roof Gable/Corbels/Bellyband/Cantilever

- Change the roof design over the master bedroom of main residence from a hip and valley roof to a gable roof.

- Add decorative wood corbels at strategic locations on the primary residence and second unit.
- Add a 2x12 wood bellyband to separate the first and second stories of the second unit on the north, south, and east building elevations.
- Add second story cantilever to the second unit on the south and east building elevations.

Color Scheme

- Change the entire color scheme for the primary residence and second unit from an earth tone color palette that utilizes beige and tan colors to a more vibrant color palette that features blue (Blueberry), brown (Leather Satchel), and white (Cloud White) colors.

The exhibits (Figures 1, 2 and 3) on the following pages show the building elevations for the 2,837-square-foot single-family residence and attached second unit that were previously approved by the Historic District Commission and the proposed building elevations.

FIGURE 1: PREVIOUSLY APPROVED BUILDING ELEVATIONS



FIGURE 2: PREVIOUSLY APPROVED BUILDING ELEVATIONS

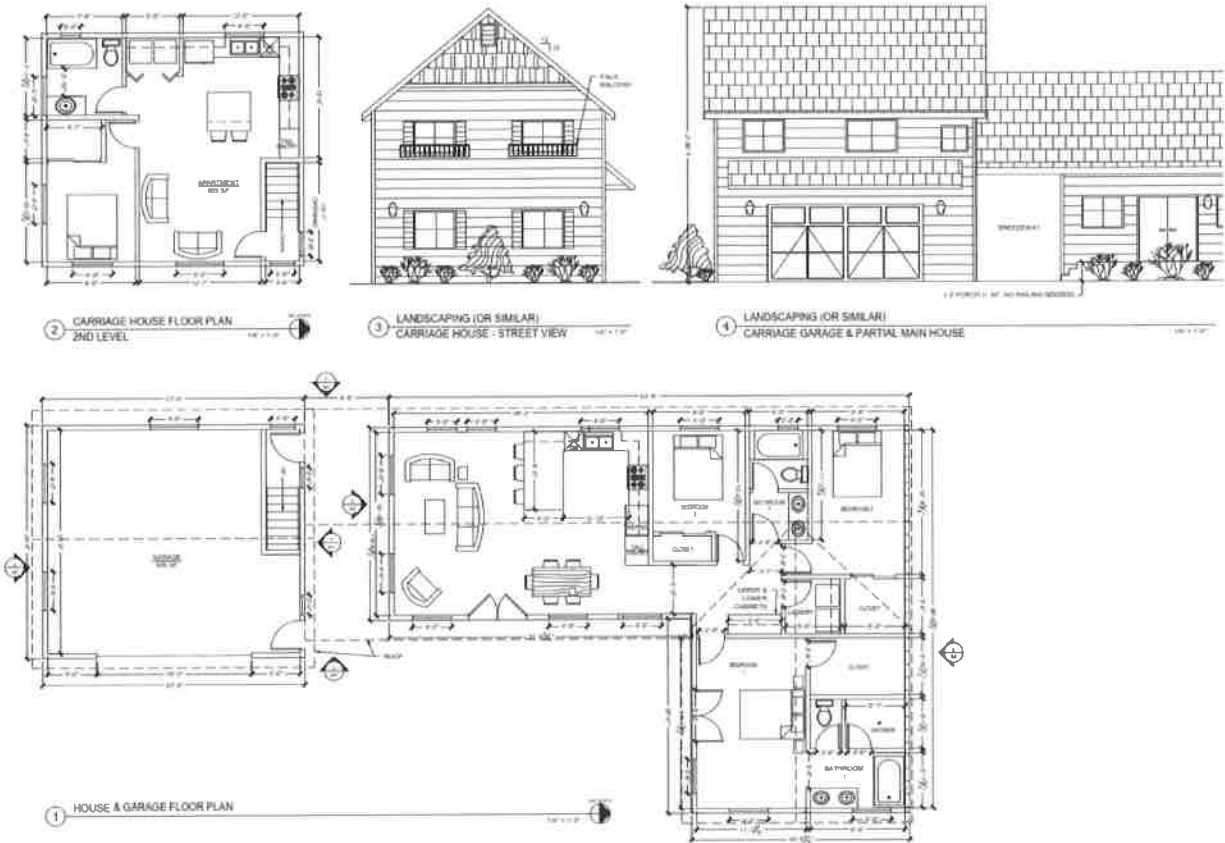

FIGURE 3: PROPOSED BUILDING ELEVATIONS



The proposed project, which is located within the Central Subarea of the Historic Residential Primary Area, is subject to the Historic District Design and Development Guidelines (Design Guidelines). The Design Guidelines provide guidance for implementation of the regulations imposed by Chapter 17.52 (Historic District) of the Folsom Municipal Code. The Design Guidelines also provide standards and procedures intended to assist in maintaining and recreating the 1850 to 1950 styles and patterns of development in the 98-block Historic District area.

The Design Guidelines state that the goal of any remodeling project is to maintain or improve a structure's value to the owner and the community by achieving good design and historic appropriateness, to the greatest extent feasible. In evaluating a request to remodel a structure, the Design Guidelines indicate that the Historic District Commission shall consider the following factors:

1. The property owner's and community's benefit.
2. The structure's architectural and historical value.

3. Resources available for historic authenticity purposes, such as historical and architectural documentation, materials availability, and financing.

The single-family residence that was previously located on the project site was constructed in 1952 and featured a Craftsman-Style design. Craftsman-style design is typically characterized by the use of prominent front porches, gable roof elements, decorative roof vents, horizontal wood siding, and wood-framed doors and windows. As shown in the submitted building elevations (Attachment 8), the proposed project incorporates a number of significant Craftsman-style design features including horizontal lap siding, wood shingle-siding, decorative roof vents, wood corbels, and wood-framed windows and doors.

The Design Guidelines for the Central Subarea include a number of recommendations relative to building materials including siding, trim, windows, doors, and roofing material. In terms of siding, the proposed project includes the use of 4-inch Hardiplank lap siding and Hardiplank wood shingles, both of which are considered acceptable materials according to the Design Guidelines. With regard to trim, the proposed project includes wood trim around all windows and doors as suggested by the Design Guidelines, as shown on the submitted plans (Attachment 8).

The Design Guidelines indicate that wood-framed double-hung or casement windows are the preferred window type for the Central Subarea. However, the Design Guidelines also state that vinyl-clad windows may be utilized for less historically significant structures. In general, window proportions should be vertical rather than horizontal; however, appropriate proportions and the number of window panes can vary depending on the style of the individual building. Regarding building entries, the Design Guidelines state that residentially-scaled and solid wood or glazed doors may be appropriate. The applicant is proposing to utilize a combination of vertically and horizontally-oriented vinyl-clad windows depending on the building elevations. The applicant is proposing to utilize a wood-framed door on the main portion of the residence and a wood-framed door for the second unit. Staff is supportive of the proposed window and door design.

The Design Guidelines state that appropriate roofing materials may include fireproof wood shingles, corrugated metal, composition fiberglass shingles, clay tile, or other materials as determined by historic evidence. Inappropriate roofing materials include colored standing seam metal roofs, glazed ceramic tile, and imitation roofing materials such as concrete shingles and imitation concrete mission tile. As recommended by the Design Guidelines, the proposed project includes the use of architectural-grade composition roof shingles.

In the Central Subarea of the Historic Residential Primary Area, the Design Guidelines suggest that garages identifiable as such are not allowed unless integral to the architectural time frame of the building's existing design. The Design Guidelines also recommend that garage doors be broken into smaller components to minimize their

visual impact. Given that the project site has no access to the Persifer Street/Bidwell Street Alley and that the existing residence is already located at the rear boundary of the parcel, the applicant had limited options in terms of placement of the attached garage. To minimize the visual impact of the garage, the applicant has oriented the garage to face east so that it would be less visible from Bidwell Street. In addition, the applicant, created a residential design for the portion of the garage facing Bidwell Street so that the structure would not be easily identifiable as a garage. Lastly, the applicant created a carriage-style design (with black-colored hardware and carriage bolts) for the garage door to create the appearance of two single garage doors as opposed to a two-car garage door.

In reviewing the proposed project as shown on the submitted building elevations, staff concluded that the proposed modifications to the exterior would result in an improved design that is more Craftsman-style in nature than the original design of the residence and second unit. In addition, staff has determined that the proposed project meets the intent of the Design Guidelines by maintaining an 1850 to 1950 appearance standard through restoration and reconstruction of the residence in an authentic manner.

Staff forwards the following design recommendations to the Commission for consideration (Condition No. 15):

1. This approval is for design modifications to a previously approved 2,837-square-foot single-family residence and attached second unit for the 908 Bidwell Street Design Modifications project. The applicant shall submit building plans that comply with this approval, the attached site plan, the attached building elevations and the attached floor plan, dated June 19, 2020, December 22, 2020, November 16, 2020, and January 29, 2021, respectively.
2. The design, materials, and colors of the proposed 908 Bidwell Street Design Modifications project shall be consistent with the submitted building elevations, material samples, and color scheme to the satisfaction of the Community Development Department.
3. The project driveway and driveway apron shall be constructed of an all-weather pervious treatment to the satisfaction of the Community Development Department.
4. Roof-mounted mechanical equipment, including satellite dish antennas, shall not extend above the height of the parapet walls. Ground-mounted mechanical equipment shall be shielded by landscaping or trellis type features.
5. All Conditions of Approval as outlined herein shall be made as a note or separate sheet on the Construction Drawings.

Parking

The Folsom Municipal Code (FMC, Section 17.52.540) requires single-family detached dwelling units are required to provide two on-site parking spaces. The parking spaces must be provided outside of required front and street side yards. The applicant is proposing two off-street parking spaces in a two-car side-load garage located adjacent to Bidwell Street. As a result, staff has determined that the proposal complies with the parking requirements established for the Central Subarea. It is important to note that there is no separate parking requirement for the attached second unit.

Project Driveway and Apron

As shown on the submitted site plan, the applicant is proposing to construct an asphalt driveway and driveway apron to provide access to the new garage. The Design Guidelines recommend that driveway improvements and other vehicular access requirements of new development be sensitive to the traditional if not historic character of the neighborhood and its existing features, and incorporate similar treatments. In general, the Design Guidelines state that accent pavements and oversized drives are not allowed within this context, although some scored concrete finishes may reflect the existing character of development. Given this guidance by the Design Guidelines, staff recommends that the project driveway and driveway apron be constructed of an all-weather pervious treatment to the satisfaction of the Community Development Department. Condition No. 15-3 is included to reflect this requirement.

Existing and Proposed Landscaping

The project site originally contained a combination of trees (Pine tree, Walnut tree, Fir tree, and ornamental fruit trees), shrubs, and groundcover. Initially, the applicant had proposed to remove all of the trees from the project site with the exception of a large Pine tree located adjacent to Bidwell Street. However, due to some structural concerns regarding the Pine tree, the applicant obtained a Tree Permit from the City and removed this tree. It is important to note that none of the trees which were removed were considered a protected tree according to the Folsom Municipal Code (FMC, Section 12.16).

As shown on the submitted site plan (Attachment 7), the applicant is proposing to plant a new tree (Maple tree) and shrubs at various locations on the project site. Staff recommends that the owner/applicant submit a landscape and irrigation plan that is subject to review and approval by the Community Development Department. Condition No. 16 is included to reflect this requirement.

Existing Site and Building Conditions

The applicant obtained a Grading Permit from the City and graded the entire project site, including the removal of all vegetation as previously mentioned within this report. The applicant also obtained a Building Permit from the City, after which the building foundation was poured, and vertical construction of the residence commenced resulting in all walls being erected and a roof put in place. The applicant has ceased construction

activities on the exterior of the residence pending Historic District Commission approval of the subject Design Review Application.

ENVIRONMENTAL REVIEW

The project is categorically exempt under Section 15301 Existing Facilities of the California Environmental Quality Act (CEQA) Guidelines.

RECOMMENDATION/HISTORIC DISTRICT COMMISSION ACTION

Staff recommends approval of the proposed project, subject to the findings included in this report (Findings A-I) and the attached conditions of approval (Conditions 1-22).

Move to Approve Design Review for exterior modifications to a previously approved 2,837-square-foot single-family residence with attached second unit as illustrated on Attachments 7 through 9 for the 908 Bidwell Street Design Review Modifications project (PN 21-059) subject to the findings (Findings A-I) and conditions of approval (Conditions 1-22) included as Attachment 3.

GENERAL FINDINGS

- A. NOTICE OF PUBLIC MEETING HAS BEEN GIVEN AT THE TIME AND IN THE MANNER REQUIRED BY STATE LAW AND CITY CODE.
- B. THE PROJECT IS CONSISTENT WITH THE GENERAL PLAN AND THE ZONING CODE OF THE CITY.

CEQA FINDINGS

- C. THE PROJECT IS CATEGORICALLY EXEMPT FROM ENVIRONMENTAL REVIEW UNDER SECTION 15301 (EXISTING FACILITIES) OF THE CALIFORNIA ENVIRONMENTAL QUALITY ACT (CEQA) GUIDELINES.
- D. THE CUMULATIVE IMPACT OF SUCCESSIVE PROJECTS OF THE SAME TYPE IN THE SAME PLACE, OVER TIME IS NOT SIGNIFICANT IN THIS CASE.
- E. NO UNUSUAL CIRCUMSTANCES EXIST TO DISTINGUISH THE PROPOSED PROJECT FROM OTHERS IN THE EXEMPT CLASS.
- F. THE PROPOSED PROJECT WILL NOT CAUSE A SUBSTANTIAL ADVERSE CHANGE IN THE SIGNIFICANCE OF A HISTORIC RESOURCE

DESIGN REVIEW FINDINGS

- G. THE PROPOSED PROJECT COMPLIES WITH THE GENERAL PLAN AND ZONING ORDINANCES OF THE CITY.

- H. THE BUILDING MATERIALS, TEXTURES AND COLORS USED IN THE PROPOSED PROJECT ARE COMPATIBLE WITH SURROUNDING DEVELOPMENT AND ARE CONSISTENT WITH THE GENERAL DESIGN THEME OF THE NEIGHBORHOOD.

- I. THE PROPOSED PROJECT IS IN CONFORMANCE WITH THE HISTORIC DISTRICT DESIGN AND DEVELOPMENT GUIDELINES ADOPTED BY CITY COUNCIL.

ATTACHMENT 2 BACKGROUND

On April 3, 2019, the Historic District Commission reviewed an application for Design Review and Variances for a 1,635-square-foot residential addition and remodel of an existing 1,202-square-foot single-family residence and demolition of an 81-square-foot accessory structure and 120-square-foot section of the existing residence located at 908 Bidwell Street. The Commission engaged in a lengthy debate regarding the proposed project and heard a significant amount of public comment.

The primary issues discussed by the Commission were the request for the rear yard and side yard setback Variances and the architectural design of the proposed residential additions. With respect to the setback Variances, a number of Commissioners expressed concern there were not sufficient grounds for granting of the proposed side yard setback Variance, while other Commissioners were satisfied that the substandard size and depth of the residential lot provided sufficient justification for the setback Variance requests.

In relation to architecture, the Commission was generally supportive of the overall design of the proposed project, however, the Commission recommended that additional architectural enhancements be made to the two-story building elevation directly facing Bidwell Street. In addition, the Commission recommended that the applicant submit a final color and materials board to City staff for review and approval. These recommendations were included as conditions of approval for the project (Condition Nos. 16-9 and 16-10). After a substantial period of deliberation, the Commission voted (3-2-1-1) to approve the proposed Design Review and Variances application.

On April 15, 2019, Paul Keast (property owner at 808 Mormon Street) submitted a timely Notice of Appeal and associated appeal letters to the Community Development Director appealing the Historic District Commission's decision to approve Variances for development of a second dwelling unit at 908 Bidwell Street. In addition to contesting the Commission's approval of the Variances associated with the second unit, Mr. Keast requesting a waiver of the \$458 appeal fee.

In the appeal letter, Mr. Keast outlined a number of reasons for contesting approval of the Variances associated with second unit at 908 Bidwell Street including; the subject property does not meet the minimum lot size requirement for having a second unit, the subject property is too small to accommodate a second unit, the second unit does not meet the minimum side yard setback requirement, the massing of the two-story portion of the residential addition adjacent to Bidwell Street is not appropriate, the project does not provide adequate on-site parking, and the financial viability of the project should not be considered a reason for granting of the Variances. On June 11, 2019, the City Council voted (5-0-0-0) to deny the appeal by Mr. Keast of the Historic District

Commission action granting Variances for the second dwelling unit at 908 Bidwell Street project (PN 18-397).

On December 30, 2019, the applicant submitted plans to the Community Development Department for approval of a Building Permit for development of the 2,837-square-foot single-family residence with attached second unit. During plan review for building code compliance for initial building permit request at 908 Bidwell, City Staff identified several challenges with the proposed plans relative to the non-conforming setbacks. As a result, staff approved minor modifications to those non-conforming walls to be more conforming and mistakenly approved more significant demolition than what was originally granted by the Historic District Commission (and City Council on appeal). During previous discussions with the Historic District Commission and City Council, City Staff explained the plan check challenges, staff approved modifications, and approved demolition error. Staff also identified actions to improve reviews, as well as checks and balances in the process moving forward. The focus of this request is on new exterior design modifications proposed by the applicant. Some of the modifications have been constructed before receiving necessary approvals. Historic District Commission review and approval is required to allow those modifications prior to any final sign off or certificate of occupancy at 908 Bidwell.

GENERAL PLAN DESIGNATION	SFHD (Single Family High Density)
ZONING	CEN/R-1-M (Central Subarea of the Historic Residential Primary Area/Single-Family Dwelling, Small Lot District)
ADJACENT LAND USES/ZONING	North: Single Family Residential Parcel (CEN/R-1-M) with the Persifer Street/Bidwell Street Alley Beyond South: Bidwell Street with Multi-Family Residential Development (CEN/R-4) Beyond East: Single-Family Residential Development (CEN/R-1-M) with Decatur Street Beyond West: Single Family Residential Development (CEN/R-1-M) with Reading Street Beyond
SITE CHARACTERISTICS	The 0.13-acre project site is currently under construction with development of a 2,837-square-foot single-family residence and attached second unit. There are no existing

trees (an existing pine tree was removed with approval of a Tree Permit by the City) or vegetation located on the project site.

APPLICABLE CODES

FMC Chapter 17.52 HD, Historic District
FMC Section 17.52.300, Design Review
FMC Section 17.52.540, Historic Residential
Primary Area Special Use and Design
Standards
FMC Section 17.52.490, Accessory Dwelling
Units
FMC Section 17.52.500, Second Units
FMC Chapter 17.105, Accessory Dwelling
Units
Historic District Design and Development
Guidelines (DDG's)

Attachment 3

Conditions of Approval

CONDITIONS OF APPROVAL FOR 908 BIDWELL STREET DESIGN MODIFICATIONS PROJECT (PN 21-059)				
908 BIDWELL STREET DESIGN REVIEW				
	Mitigation Measure	Condition/Mitigation Measure	When Required	Responsible Department
1.		<p>The applicant shall submit final site development plans to the Community Development Department that shall substantially conform to the exhibits referenced below:</p> <ul style="list-style-type: none"> • Site Plan, dated June 19, 2020 • Building Elevations and Floor Plan, dated December 22, 2020, November 16, 2020 and January 29, 2021 <p>This project approval is for the 908 Bidwell Street Design Modifications project, which includes minor changes the number, location, and size of windows on all four building elevations, the addition of wood trim around all windows and doors, relocation of the front door on the primary residence, relocation of the front door and staircase on the second unit, roof modifications to a portion of the main residence, adding a cantilever element to the second unit, adding a bellyband to the second unit, altering the design of the garage door, and changing the color scheme of the primary residence and second unit. Implementation of the project shall be consistent with the above-referenced items as modified by these conditions of approval.</p>	B	CD (P)(E)
2.		<p>Building plans shall be submitted to the Community Development Department for review and approval to ensure conformance with this approval and with relevant codes, policies, standards and other requirements of the City of Folsom.</p>	B	CD (P)(E)(B)
3.		<p>The project approval granted under this staff report (Design Review) shall remain in effect for one year from final date of approval (April 21, 2022). Failure to obtain the relevant building (or other) permits within this time period, without the subsequent extension of this approval, shall result in the termination of this approval.</p>	B	CD (P)

CONDITIONS OF APPROVAL FOR 908 BIDWELL STREET DESIGN MODIFICATIONS PROJECT (PN 21-059)				
908 BIDWELL STREET DESIGN REVIEW				
	Mitigation Measure	Condition/Mitigation Measure	When Required	Responsible Department
4.		<p>The owner/applicant shall defend, indemnify, and hold harmless the City and its agents, officers and employees from any claim, action or proceeding against the City or its agents, officers or employees to attack, set aside, void, or annul any approval by the City or any of its agencies, departments, commissions, agents, officers, employees, or legislative body concerning the project. The City will promptly notify the owner/applicant of any such claim, action or proceeding, and will cooperate fully in the defense. The City may, within its unlimited discretion, participate in the defense of any such claim, action or proceeding if both of the following occur:</p> <ul style="list-style-type: none"> • The City bears its own attorney’s fees and costs; and • The City defends the claim, action or proceeding in good faith <p>The owner/applicant shall not be required to pay or perform any settlement of such claim, action or proceeding unless the settlement is approved by the owner/applicant.</p>	OG	CD (P)(E)(B) PW, PR, FD, PD, NS
DEVELOPMENT COSTS AND FEE REQUIREMENTS				
5.		The owner/applicant shall pay all applicable taxes, fees and charges at the rate and amount in effect at the time such taxes, fees and charges become due and payable.	B	CD (P)(E)
6.		If applicable, the owner/applicant shall pay off any existing assessments against the property, or file necessary segregation request and pay applicable fees.	B	CD (E)
7.		The City, at its sole discretion, may utilize the services of outside legal counsel to assist in the implementation of this project, including, but not limited to, drafting, reviewing and/or revising agreements and/or other documentation for the project. If the City utilizes the services of such outside legal counsel, the applicant shall reimburse the City for all outside legal fees and costs incurred by the City for such services. The applicant may be required, at the sole discretion of the City Attorney, to submit a deposit to the City for these services prior to initiation of the services. The applicant shall be responsible for reimbursement to the City for the services regardless of whether a deposit is required.	B	CD (P)(E)

CONDITIONS OF APPROVAL FOR 908 BIDWELL STREET DESIGN MODIFICATIONS PROJECT (PN 21-059)				
908 BIDWELL STREET DESIGN REVIEW				
	Mitigation Measure	Condition/Mitigation Measure	When Required	Responsible Department
8.		If the City utilizes the services of consultants to prepare special studies or provide specialized design review or inspection services for the project, the applicant shall reimburse the City for actual costs it incurs in utilizing these services, including administrative costs for City personnel. A deposit for these services shall be provided prior to initiating review of the Final Map, improvement plans, or beginning inspection, whichever is applicable.	B	CD (P)(E)
9.		This project shall be subject to all City-wide development impact fees, unless exempt by previous agreement. This project shall be subject to all City-wide development impact fees in effect at such time that a building permit is issued. These fees may include, but are not limited to, fees for fire protection, park facilities, park equipment, Humbug-Willow Creek Parkway, Light Rail, TSM, capital facilities and traffic impacts. The 90-day protest period for all fees, dedications, reservations or other exactions imposed on this project will begin on the date of final approval (April 21, 2021). The fees shall be calculated at the fee rate in effect at the time of building permit issuance.	B	CD (P)(E), PW, PK
10.		The owner/applicant agrees to pay to the Folsom-Cordova Unified School District the maximum fee authorized by law for the construction and/or reconstruction of school facilities. The applicable fee shall be the fee established by the School District that is in effect at the time of the issuance of a building permit. Specifically, the owner/applicant agrees to pay any and all fees and charges and comply with any and all dedications or other requirements authorized under Section 17620 of the Education Code; Chapter 4.7 (commencing with Section 65970) of the Government Code; and Sections 65995, 65995.5 and 65995.7 of the Government Code.	B	CD (P)
11.		If applicable, the owner/applicant shall pay off any existing assessments against the property, or file necessary segregation request and pay applicable fees.	B	CD (E)
SITE DEVELOPMENT REQUIREMENTS				
12.		The improvement plans for the required private improvements shall be reviewed and approved by the Community Development Department prior to issuance of the Building Permit.	B	CD (E)

CONDITIONS OF APPROVAL FOR 908 BIDWELL STREET DESIGN MODIFICATIONS PROJECT (PN 21-059)				
908 BIDWELL STREET DESIGN REVIEW				
	Mitigation Measure	Condition/Mitigation Measure	When Required	Responsible Department
13.		The owner/applicant shall coordinate the planning, development and completion of this project with the various utility agencies (i.e., SMUD, PG&E, etc.).	I	CD (P)(E)
STORM WATER POLLUTION/CLEAN WATER ACT REQUIREMENTS				
14.		During Construction, the owner/applicant shall be responsible for litter control and sweeping of all paved surfaces in accordance with City standards. All on-site storm drains shall be cleaned immediately before the commencement of the rainy season (October 15).	G, I, B	CD (E)

ARCHITECTURE/SITE DESIGN REQUIREMENTS

15.		<p>The project shall comply with the following architecture and design requirements:</p> <ol style="list-style-type: none"> 1. This approval is for design modifications to a previously approved 2,837-square-foot single-family residence and attached second unit for the 908 Bidwell Street Design Modifications project. The applicant shall submit building plans that comply with this approval, the attached site plan, the attached building elevations and the attached floor plan, dated June 19, 2020, December 22, 2020, November 16, 2020, January 29, 2021, respectively. 2. The design, materials, and colors of the proposed 908 Bidwell Street Design Modifications project shall be consistent with the submitted building elevations, material samples, and color scheme to the satisfaction of the Community Development Department. 3. The project driveway and driveway apron shall be constructed of an all-weather pervious treatment to the satisfaction of the Community Development Department. 4. Roof-mounted mechanical equipment, including satellite dish antennas, shall not extend above the height of the parapet walls. Ground-mounted mechanical equipment shall be shielded by landscaping or trellis type features. 5. All Conditions of Approval as outlined herein shall be made as a note or separate sheet on the Construction Drawings. 	B	CD (P) (B)
-----	--	---	---	------------

LANDSCAPE/TREE PRESERVATION REQUIREMENTS

16.		<p>Pursuant to the state’s Model Water Efficient Landscape Ordinance (MWELo), all new construction projects with an aggregate front yard landscape area equal to or greater than 500 square feet shall submit a landscape documentation package and landscape permit application to the CDD for review and approval. The landscape permit shall be issued prior to, or at the time of, the issuance of a building permit.</p> <p>Projects with an aggregate front yard landscape area of 500 to 2,500 square feet may either:</p> <p>a) Comply with the performance requirements of the MWELo and within 24 months of the date of landscape permit issuance shall install the City-approved landscape and submit a Certificate of Completion to the CDD; or</p> <p>b) Comply with the simpler Prescriptive Compliance Option contained in Appendix D to the MWELo and, by the time of final inspection for a Building Permit for the home, shall install the City-approved landscape and submit a Certificate of Completion to the CDD.</p> <p>Projects with an aggregate front yard landscape area of more than 2,500 square feet shall comply with the performance requirements of the MWELo and within 24 months of the date of landscape permit issuance shall install the City-approved landscape and submit a Certificate of Completion to the CDD.</p>	I	CD (P)(E)
-----	--	---	---	-----------

16. Cont.		<p>Projects with an aggregate front yard landscape area of less than 500 square feet shall submit a preliminary landscape plan to the CDD for review and approval prior to, or at the time of, the issuance of a building permit. The preliminary landscape plan shall show all proposed front yard landscaping with irrigated planting areas, plant materials, street tree species and location, footprints of buildings or structures, sidewalks, driveways, decks, patios, gravel or stone walks, or other pervious or non-pervious hardscapes, and other non-irrigated areas designated for non-development (such as open spaces and existing native vegetation). The preliminary landscape plan shall also include the calculation of front yard landscape area consistent with the definition herein. The City-approved landscaping shall be installed within 24 months of the date of building permit issuance.</p> <p>Any significant modification to the City-approved landscaping shall comply with the State's Model Water Efficient Landscape Ordinance.</p> <p>For purposes of this condition of approval, "landscape area" means all the irrigated planting areas, irrigated turf areas, and water features in a landscape design plan or preliminary landscape plan. The landscape area does not include footprints of buildings or structures, sidewalks, driveways, parking lots, decks, patios, gravel or stone walks, other pervious or non-pervious hardscapes, and other non-irrigated areas designated for non-development (e.g., open spaces and existing native vegetation).</p>	I	CD (P)(E)
NOISE REQUIREMENT				
17.		<p>Compliance with Noise Control Ordinance and General Plan Noise Element shall be required. Hours of construction operation shall be limited from 7:00 a.m. to 6:00 p.m. on weekdays and 8:00 a.m. to 5:00 p.m. on Saturdays. No construction is permitted on Sundays or holidays. In addition, construction equipment shall be muffled and shrouded to minimize noise levels.</p>	I, B	CD (P)(E)

CULTURAL RESOURCE REQUIREMENTS

18.		If any archaeological, cultural, or historical resources or artifacts, or other features are discovered during the course of construction anywhere on the project site, work shall be suspended in that location until a qualified professional archaeologist assesses the significance of the discovery and provides consultation with the Folsom Historical Society, City staff, and the Heritage Preservation League. Appropriate mitigation as recommended by the archaeologist and the Historical Society representative shall be implemented. If agreement cannot be met, the Historic District Commission shall determine the appropriate implementation method.	G, I, B	CD (P)(E)(B)
19.		In the event human remains are discovered, California Health and Safety Code Section 7050.5 states that no further disturbance shall occur until the county coroner has made the necessary findings as to the origin and disposition pursuant to Public Resources Code 5097.98. If the coroner determines that no investigation of the cause of death is required and if the remains are of Native American Origin, the coroner will notify the Native American Heritage Commission, which in turn will inform a most likely decedent. The decedent will then recommend to the landowner or landowner's representative appropriate disposition of the remains and any grave goods.	G, I, B	CD (P)(E)(B)
20.		Discovery of unknown contaminated soils during construction. If during construction, currently unknown contaminated soils are discovered (i.e., discolored soils, odorous, other indications), construction within the area shall be halted, the extent and type of contamination shall be characterized, and a clean-up plan shall be prepared and executed. The plan shall require remediation of contaminated soils. The plan shall be subject to the review and approval of SCEMD, RWQCB, the City of Folsom, or other agencies, as appropriate. Remediation can include in-situ treatment, disposal at an approved landfill, or other disposal methods, as approved. Construction can proceed within the subject area upon approval of and in accordance with the plan.	G, I, B	CD (P)(E)(B)
OTHER AGENCY REQUIREMENTS				
21.		The owner/applicant shall obtain all required State and Federal permits and provide evidence that said permits have been obtained, or that the permit is not required, subject to staff review and approval of any grading or improvement plan.	I, G	CD (P)(E)
22.		The owner/applicant shall obtain permission (permit, letter, agreement, etc.) from all applicable public utility companies (SMUD, PG&E, WAPA, etc.) in a form acceptable to the Community Development Department for construction-related activities proposed within the existing public utility easements.	I	CD (P)

CONDITIONS

See attached tables of conditions for which the following legend applies.

RESPONSIBLE DEPARTMENT		WHEN REQUIRED	
CD	Community Development Department	I	Prior to approval of Improvement Plans
(P)	Planning Division	M	Prior to approval of Final Map
(E)	Engineering Division	B	Prior to issuance of first Building Permit
(B)	Building Division	O	Prior to approval of Occupancy Permit
(F)	Fire Division	G	Prior to issuance of Grading Permit
PW	Public Works Department	DC	During construction
PR	Park and Recreation Department	OG	On-going requirement
PD	Police Department		

Attachment 4
Vicinity Map

Vicinity Map



CITY OF
FOLSOM

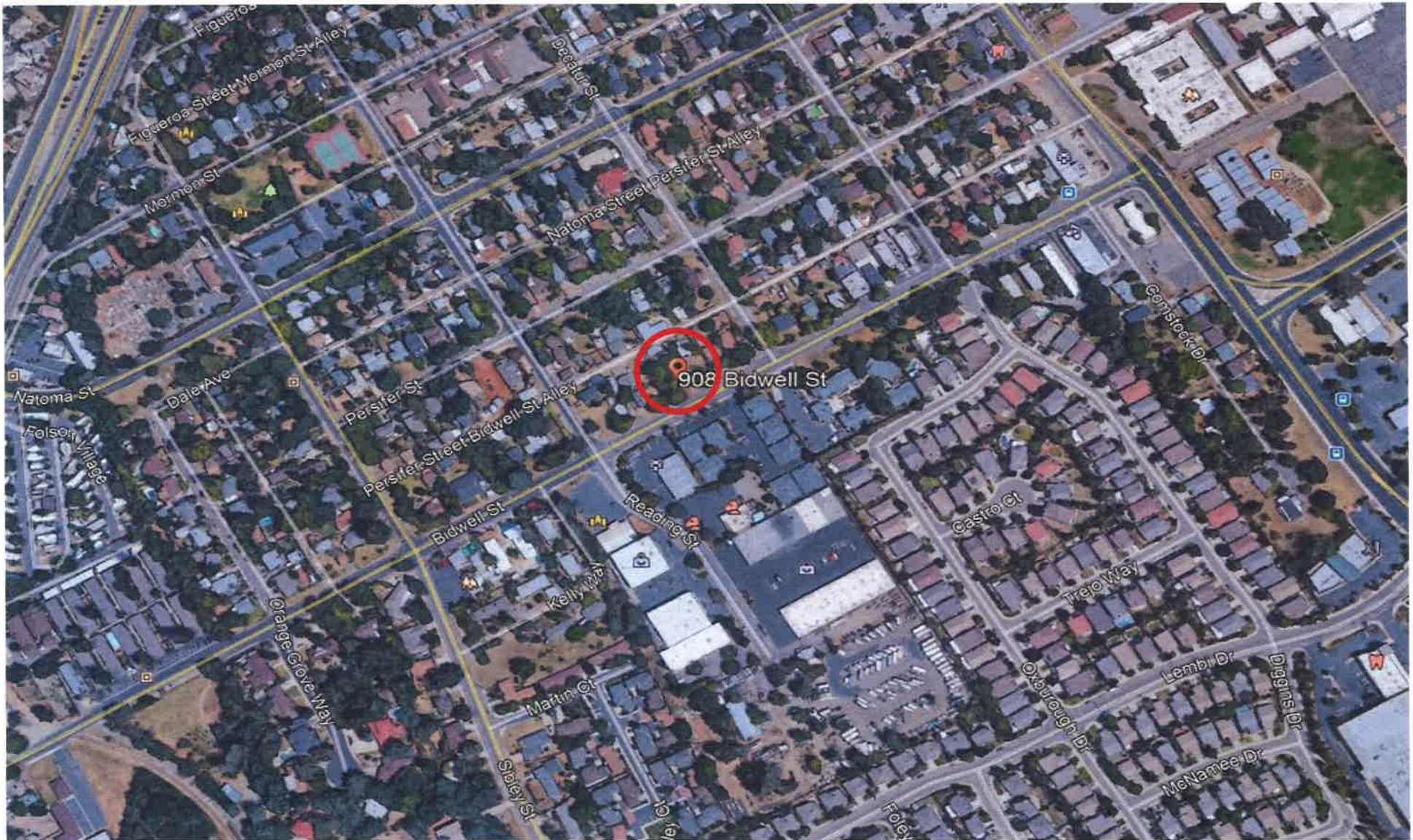

Attachment 5

Previously Approved Site Plan Dated September 17, 2018

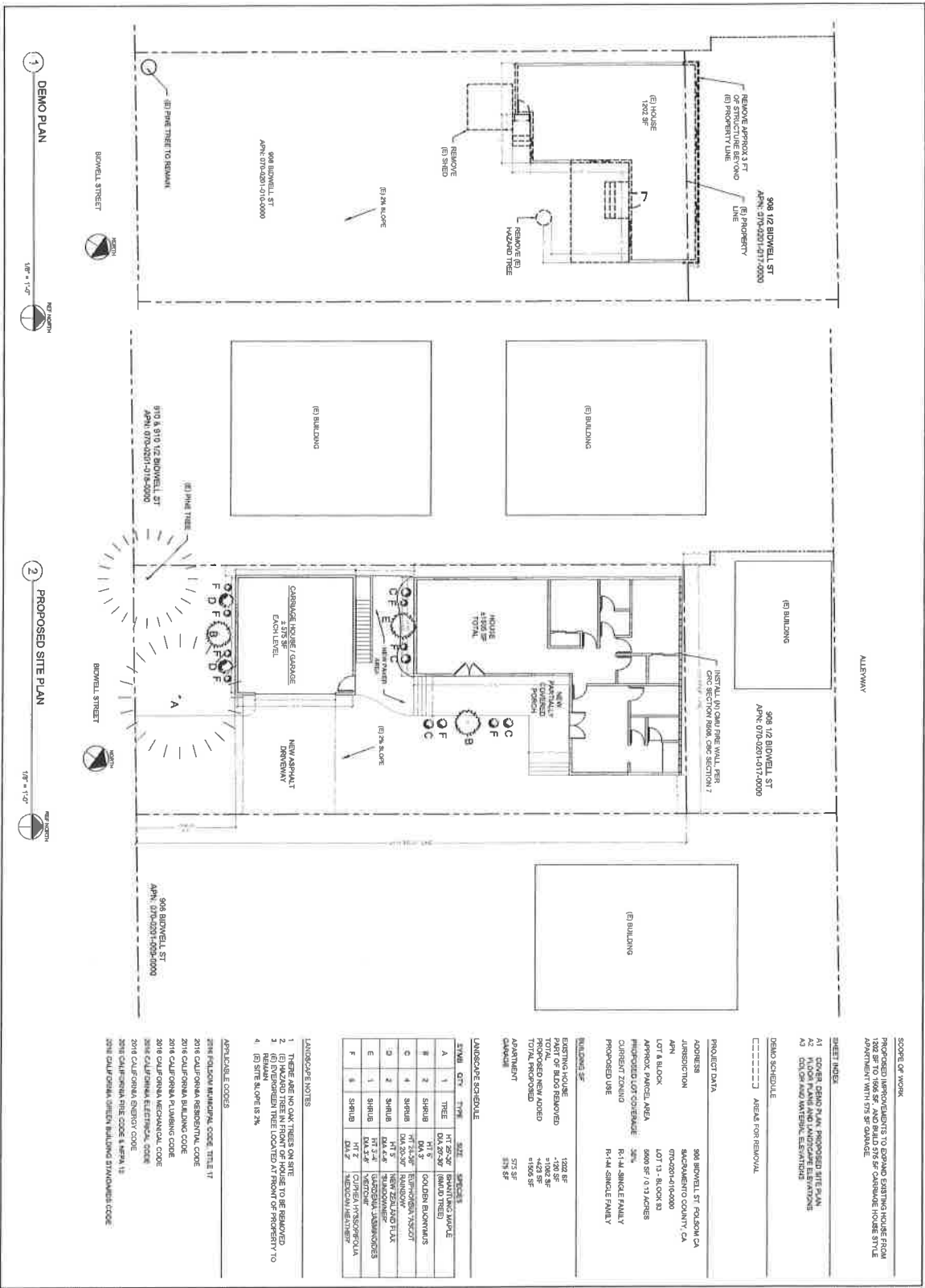

Attachment 6

Previously Approved Building Elevations and Floor Plans, dated September 17, 2018

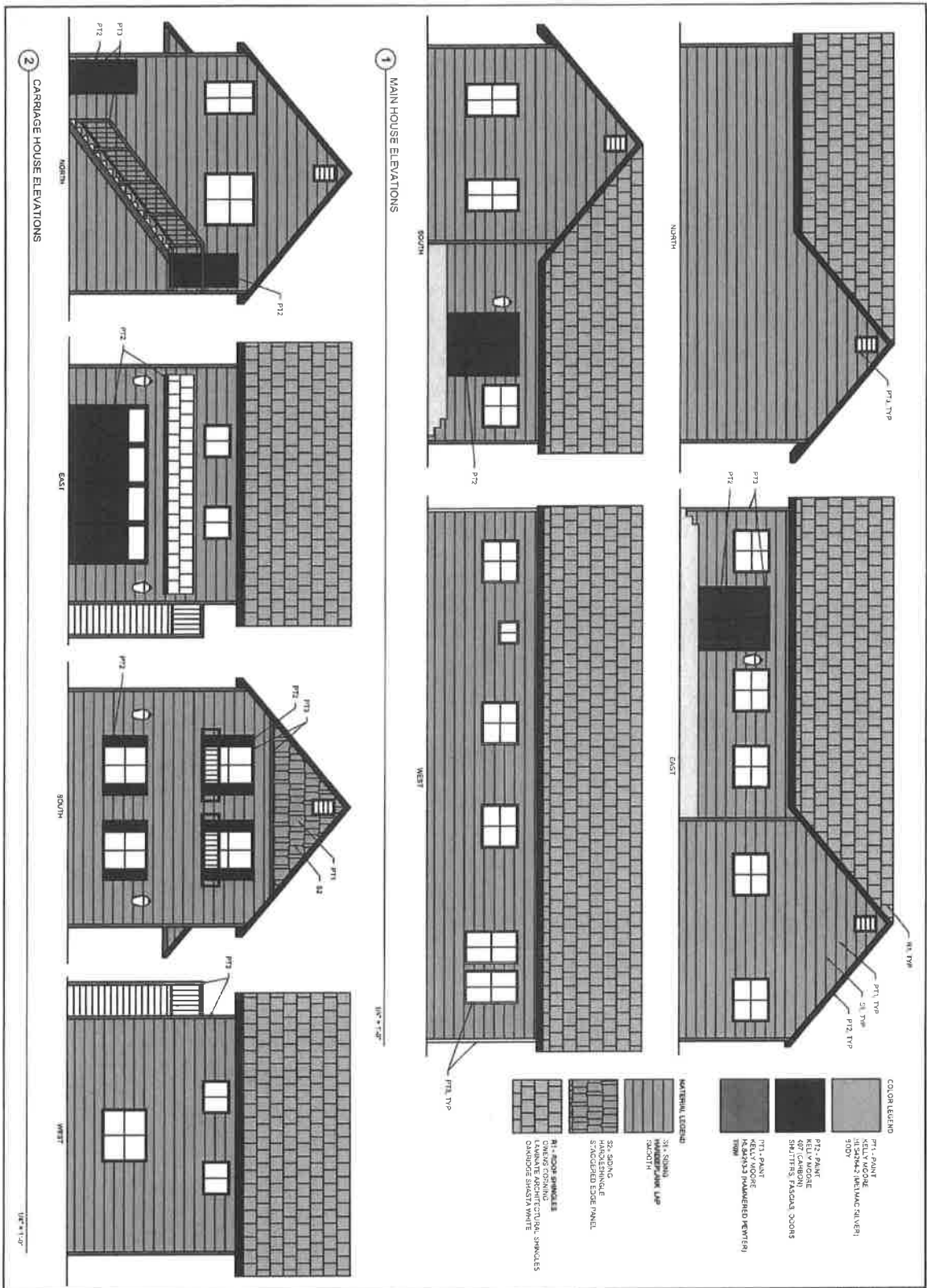

<p>REVISIONS</p> <table border="1"> <tr> <th>NO.</th> <th>DESCRIPTION</th> </tr> <tr> <td> </td> <td> </td> </tr> <tr> <td> </td> <td> </td> </tr> </table>	NO.	DESCRIPTION					<p>OWNER</p> <p>BRIAN MARTELL 222 Wellfleet Circle Folsom, CA 95630 brianmartell@kw.com 916-804-0908</p>	<p>PROJECT</p> <p>Proposed Improvements 908 BIDWELL STREET Folsom CA 95630</p>	<p>DESIGN CONTENTS</p> <p>COLOR AND MATERIAL ELEVATIONS</p> <p>DATE: 07/15/2024 DRAWN BY: [Name] CHECKED BY: [Name] JOB NO: [Number] SHEET: [Number]</p>	<p>A3</p>
	NO.	DESCRIPTION								
<p> </p>										

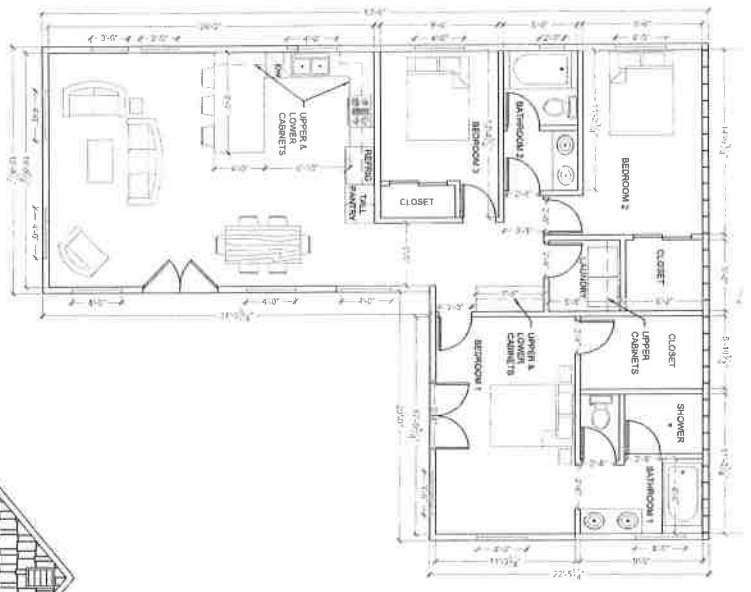

1 HOUSE FLOOR PLAN
1/4" = 1'-0"



2 CARRIAGE HOUSE FLOOR PLAN
1/4" = 1'-0"

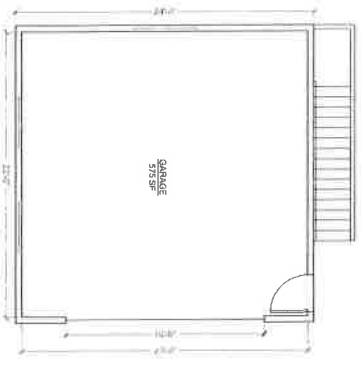

3 CARRIAGE HOUSE GARAGE PLAN
1/4" = 1'-0"

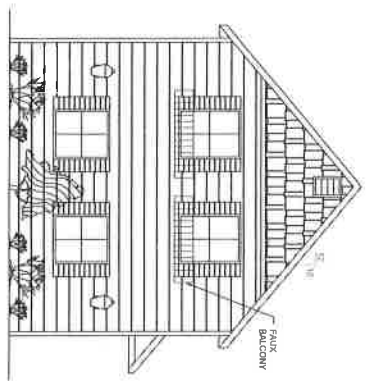

4 LANDSCAPING (OR SIMILAR)
CARRIAGE HOUSE - STREET VIEW
1/4" = 1'-0"

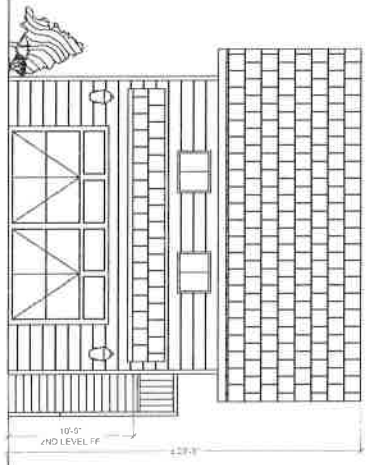

5 LANDSCAPING (OR SIMILAR)
CARRIAGE GARAGE & PARTIAL MAIN HOUSE
1/4" = 1'-0"

A2	SHEET CONTENTS: FLOOR PLANS & LANDSCAPE ELEVATIONS	PROJECT: Proposed Improvements 908 BIDWELL STREET Folsom CA 95630	OWNER: BRIAN MARTELL 222 Wellfleet Circle Folsom, CA 95630 brianmartell@icw.com 916-904-0908	REVISIONS BY
	DATE: 01/14/14 DRAWN BY: JF CHECKED BY: JF SCALE: 1/4" = 1'-0"			

Attachment 7

Site Plan, dated June 19, 2020

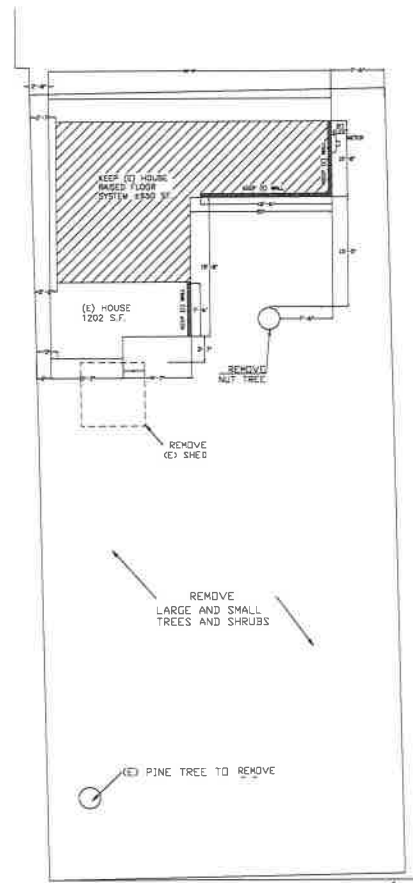

DEMO PLAN
SCALE 1/8"=1'-0"

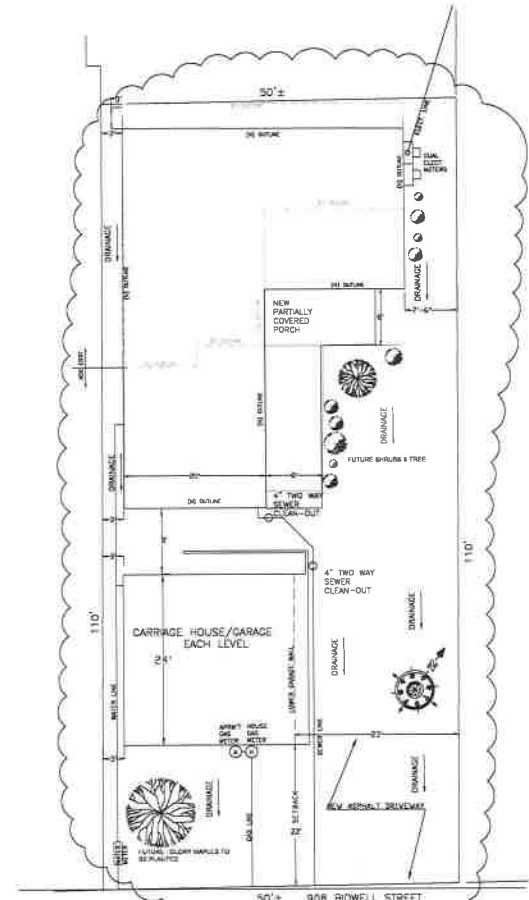

SITE PLAN
SCALE 1/8"=1'-0"

NOTE:
1. LOT DRAINAGE SHALL BE GRADED TO DRAIN SURFACE WATER AWAY FROM FOUNDATION WALLS A MIN. OF 6" WITHIN THE FIRST 10'.
2. ROOF EAVE FIRE-RESISTANCE RATING SHALL BE PERMITTED TO BE REDUCED TO 0 HOURS ON THE UNDERSIDE OF THE EAVE IF FIRE BLOCKING IS PROVIDED FROM THE WALL TOP PLATE TO THE UNDERSIDE OF THE ROOF SHEATHING.

LAN LINVILLE
DRAFTING SERVICES
901 SUNRISE AVE. SUITE 8-10
ROSELVILLE, GA.
(916) 773-2020
LICENSE # 341041
lanlinville@hotmail.com

THE DESIGNER, LAN LINVILLE, HEREBY RESERVES THE COMMON LAW COPY RIGHTS & OTHER PROPERTY RIGHTS IN THESE PLANS. NO REPRODUCTION OR REUSE IN ANY MANNER IS PERMITTED WITHOUT THE WRITTEN CONSENT OF THE DESIGNER.

REV	DATE	NAME
1	1-20-2020	SEC
2	6-18-2020	SEC

MARTELL RESIDENCE
908 BIDWELL STREET
FOLSOM, CA. 95630
DEMO/SITE PLAN

DATE JOB #
JOB # 071819
DATE 2020
BY LAN LINVILLE
SHEET # A-1.1

Attachment 8

Building Elevations and Floor Plan Dated December 22, 2020, November 16, 2020, and January 29, 2021



NORTH ELEVATION

EAST ELEVATION

SOUTH ELEVATION

WEST ELEVATION



NORTH ELEVATION

WEST ELEVATION



SOUTH ELEVATION

EAST ELEVATION

- COLOR LEGEND**
- SLUEBY (LEVERMORE) (WELLYMOORE) BODY
 - LEATHER-KATONIA (WELLYMOORE) (SINGLE PAINT) STAIN
 - CLOUD-WHITE (WELLYMOORE) TRIM
- MATERIAL LEGEND**
- S1 - SIDING (HARDPLANK) LAP SMOOTH
 - S2 - SIDING (HARDPANEL) STAGGERED EDGE PANEL
 - R1 - ROOF (SHINGLES) CERTAINTED LAMINATE (RIGHTED TURN) (SHINGLES) UNDERLAY (MOORE) SLACK

ARTIST'S RENDERING

LAN LINVILLE
 DRAFTING SERVICES
 901 SUNRISE AVE. SUITE 8-10
 ROCKVILLE, CA
 (918) 773-2020
 LICENSE # 541041
 lanlinville@att.net

NO.	DATE	BY	SCALE
1	11-28-2019	LAN	AS SHOWN
2	8-19-2020	LAN	AS SHOWN
3	11-18-2020	LAN	AS SHOWN
4	12-07-2020	LAN	AS SHOWN

MARTELL RESIDENCE
 908 BIDWELL STREET
 FOLSOM, CA. 95630
 ELEVATIONS

JOB #	071919
DATE	2018
BY	LAN LINVILLE
SHEET #	A-5.0

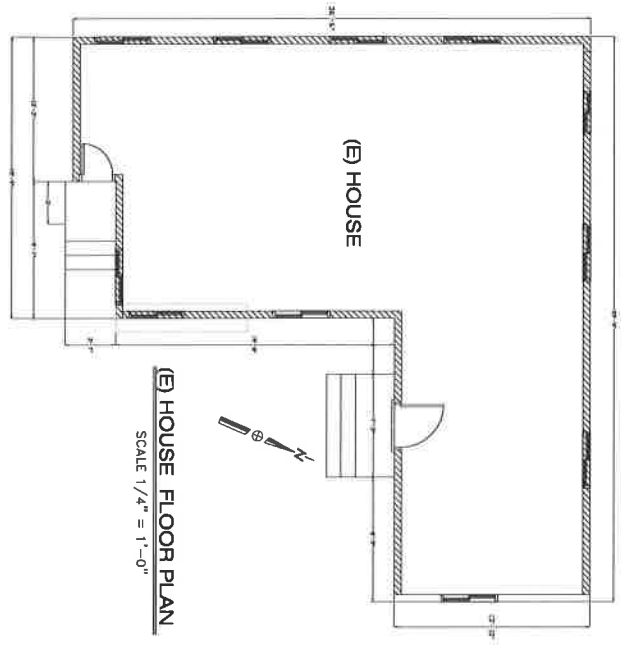

(E) HOUSE FLOOR PLAN
SCALE 1/4" = 1'-0"

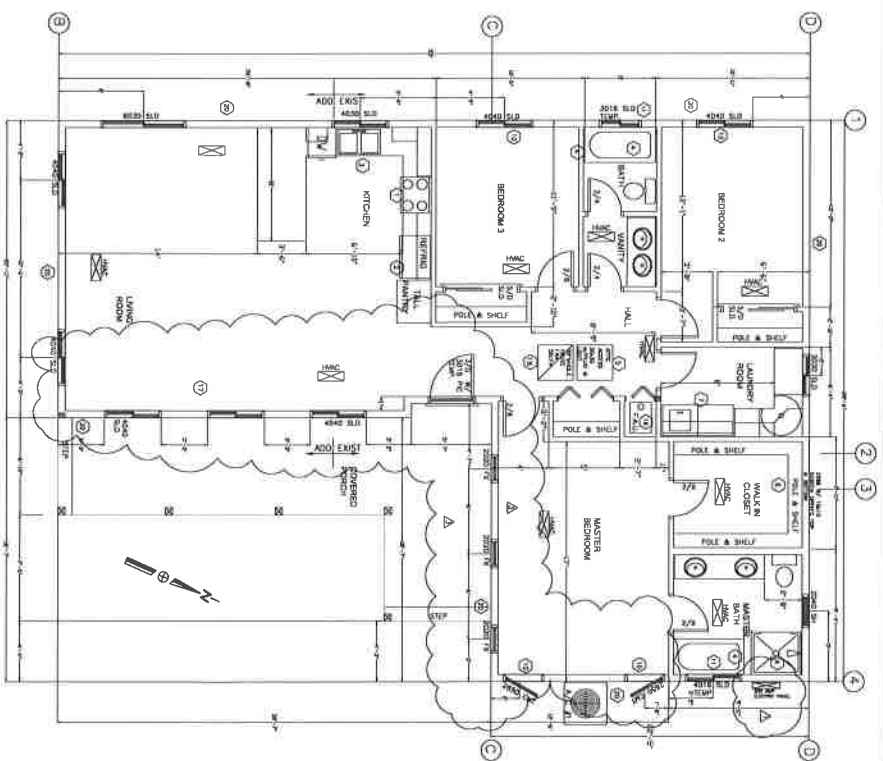
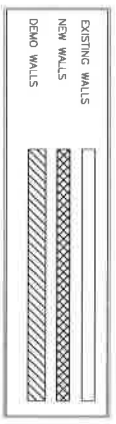

(M) HOUSE FLOOR PLAN
SCALE 1/4" = 1'-0"

NOTES:
1. HAZARDOUS MATERIALS SHALL BE IDENTIFIED IN THE HAZARDOUS MATERIALS REPORT AND SHALL BE REMOVED AND DISPOSED OF IN ACCORDANCE WITH ALL APPLICABLE REGULATIONS.
2. ALL UTILITIES AND SPECIAL MATERIALS SHALL BE IDENTIFIED IN THE HAZARDOUS MATERIALS REPORT AND SHALL BE REMOVED AND DISPOSED OF IN ACCORDANCE WITH ALL APPLICABLE REGULATIONS.
3. ALL UTILITIES AND SPECIAL MATERIALS SHALL BE IDENTIFIED IN THE HAZARDOUS MATERIALS REPORT AND SHALL BE REMOVED AND DISPOSED OF IN ACCORDANCE WITH ALL APPLICABLE REGULATIONS.
4. ALL UTILITIES AND SPECIAL MATERIALS SHALL BE IDENTIFIED IN THE HAZARDOUS MATERIALS REPORT AND SHALL BE REMOVED AND DISPOSED OF IN ACCORDANCE WITH ALL APPLICABLE REGULATIONS.
5. ALL UTILITIES AND SPECIAL MATERIALS SHALL BE IDENTIFIED IN THE HAZARDOUS MATERIALS REPORT AND SHALL BE REMOVED AND DISPOSED OF IN ACCORDANCE WITH ALL APPLICABLE REGULATIONS.

GREEN PLUMBING UPDATES
1. REPAIR AND REPLACE ALL EXISTING PLUMBING FITTINGS AND CONNECTIONS THAT DO NOT MEET THE REQUIREMENTS OF THE 2015 UPC.
2. INSTALL NEW PLUMBING FITTINGS AND CONNECTIONS THAT DO NOT MEET THE REQUIREMENTS OF THE 2015 UPC.
3. INSTALL NEW PLUMBING FITTINGS AND CONNECTIONS THAT DO NOT MEET THE REQUIREMENTS OF THE 2015 UPC.
4. INSTALL NEW PLUMBING FITTINGS AND CONNECTIONS THAT DO NOT MEET THE REQUIREMENTS OF THE 2015 UPC.
5. INSTALL NEW PLUMBING FITTINGS AND CONNECTIONS THAT DO NOT MEET THE REQUIREMENTS OF THE 2015 UPC.

ADDITIONAL FLOOR PLAN NOTES:
1. ALL DIMENSIONS ARE TO FACE UNLESS OTHERWISE NOTED.
2. ALL DIMENSIONS ARE TO FACE UNLESS OTHERWISE NOTED.
3. ALL DIMENSIONS ARE TO FACE UNLESS OTHERWISE NOTED.
4. ALL DIMENSIONS ARE TO FACE UNLESS OTHERWISE NOTED.
5. ALL DIMENSIONS ARE TO FACE UNLESS OTHERWISE NOTED.

ADDITIONAL FLOOR PLAN NOTES:
1. ALL DIMENSIONS ARE TO FACE UNLESS OTHERWISE NOTED.
2. ALL DIMENSIONS ARE TO FACE UNLESS OTHERWISE NOTED.
3. ALL DIMENSIONS ARE TO FACE UNLESS OTHERWISE NOTED.
4. ALL DIMENSIONS ARE TO FACE UNLESS OTHERWISE NOTED.
5. ALL DIMENSIONS ARE TO FACE UNLESS OTHERWISE NOTED.

JOB #	07818
SHEET	2018
DATE	1/14/2021
BY	LAN UNVILLE
REV	A-3.0

MARTELL RESIDENCE
HOUSE FLOOR PLAN
908 BIDWELL STREET
FOLSOM, CA. 95630

NO. 1	DATE	NAME
1	1/14/2021	LAN UNVILLE
2	1/14/2021	LAN UNVILLE
3	1/14/2021	LAN UNVILLE
4	1/14/2021	LAN UNVILLE
5	1/14/2021	LAN UNVILLE

LAN UNVILLE
DRAFTING SERVICES
101 E. BISHOP
SAN FRANCISCO, CA 94102
(415) 775-2020
LAN@lanunville.com

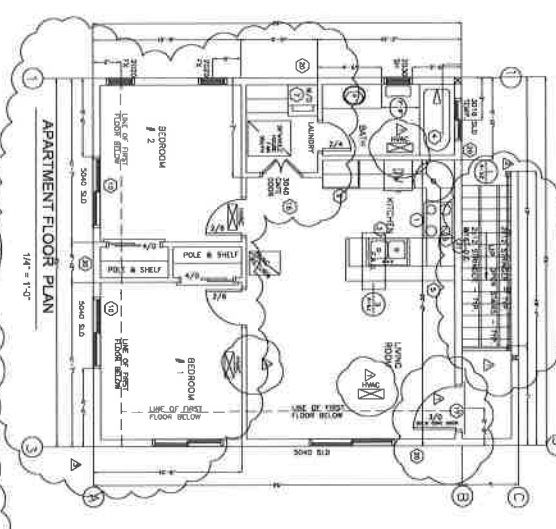
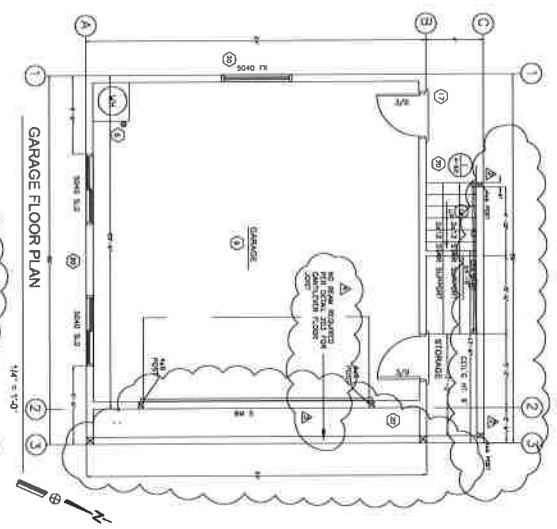

NOTES:
 1. ALL DIMENSIONS ARE UNLESS OTHERWISE NOTED.
 2. FINISH FLOOR IS 1/2\"/>

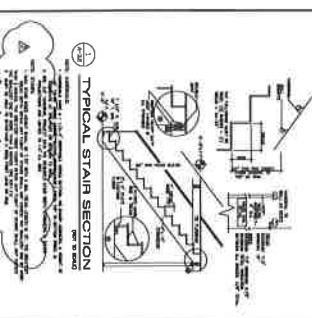

- ADDITIONAL FLOOR PLAN NOTES:**
1. FINISH FLOOR IS 1/2" ABOVE FINISH GRADE UNLESS OTHERWISE NOTED.
 2. ALL DIMENSIONS ARE UNLESS OTHERWISE NOTED.
 3. FINISH GRADE IS 1/2" ABOVE FINISH GRADE UNLESS OTHERWISE NOTED.
 4. FINISH GRADE IS 1/2" ABOVE FINISH GRADE UNLESS OTHERWISE NOTED.
 5. FINISH GRADE IS 1/2" ABOVE FINISH GRADE UNLESS OTHERWISE NOTED.
 6. FINISH GRADE IS 1/2" ABOVE FINISH GRADE UNLESS OTHERWISE NOTED.
 7. FINISH GRADE IS 1/2" ABOVE FINISH GRADE UNLESS OTHERWISE NOTED.
 8. FINISH GRADE IS 1/2" ABOVE FINISH GRADE UNLESS OTHERWISE NOTED.
 9. FINISH GRADE IS 1/2" ABOVE FINISH GRADE UNLESS OTHERWISE NOTED.
 10. FINISH GRADE IS 1/2" ABOVE FINISH GRADE UNLESS OTHERWISE NOTED.
 11. FINISH GRADE IS 1/2" ABOVE FINISH GRADE UNLESS OTHERWISE NOTED.
 12. FINISH GRADE IS 1/2" ABOVE FINISH GRADE UNLESS OTHERWISE NOTED.
 13. FINISH GRADE IS 1/2" ABOVE FINISH GRADE UNLESS OTHERWISE NOTED.
 14. FINISH GRADE IS 1/2" ABOVE FINISH GRADE UNLESS OTHERWISE NOTED.
 15. FINISH GRADE IS 1/2" ABOVE FINISH GRADE UNLESS OTHERWISE NOTED.
 16. FINISH GRADE IS 1/2" ABOVE FINISH GRADE UNLESS OTHERWISE NOTED.
 17. FINISH GRADE IS 1/2" ABOVE FINISH GRADE UNLESS OTHERWISE NOTED.
 18. FINISH GRADE IS 1/2" ABOVE FINISH GRADE UNLESS OTHERWISE NOTED.
 19. FINISH GRADE IS 1/2" ABOVE FINISH GRADE UNLESS OTHERWISE NOTED.
 20. FINISH GRADE IS 1/2" ABOVE FINISH GRADE UNLESS OTHERWISE NOTED.

MARTELL RESIDENCE

908 BIDWELL STREET
FOLSOM, CA. 95630

CARRIAGE HOUSE/GARAGE FLOOR PLAN

LAN LINVILLE
 DRAFTING SERVICES
 801 SUNSHINE AVE. SUITE 200
 FOLSOM, CA 95630
 (916) 775-2030
 LICENSE # 54583

SHEET # 07/819
 DATE 2018
 BY LAN LINVILLE
A-3.2

Attachment 9

Color and Materials Board



Integrity is ingrained
IN EVERYTHING WE DO.

HardiePlank®
Lap Siding
Composite



UNMATCHED INVESTMENT IN MANUFACTURING SCALE AND PRODUCT INNOVATION

- Largest manufacturer of fiber cement in North America
- 5x more capacity than our largest competitor
- More than 100 process and product quality checks
- 100+ scientists and engineers provide dedicated resources for continuous innovation in manufacturing and product development
- More U.S. fiber cement patents than any competitor



RUSTICSERIES™
By Woodtone

Be involved in the design process, we'll help you create your *forever home.*

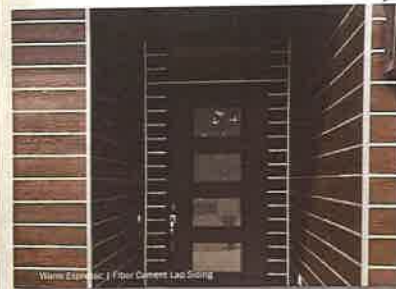

Warm Espresso | Fiber Cement Lap Siding



Summit Red | Fiber Cement Lap Siding



Summer White | Fiber Cement Lap Siding



woodtone.com

Attachment 10

Project Narrative, dated March 25, 2021

3.25.21

908 BIDWELL ST FOLSOM CA 95630 PROJECT NARRATIVE FOR THE CHANGES OF ELEVATIONS.

A.WINDOW CHANGES:

1. **EAST ELEVATION (GABLE SIDE):** Eliminating 2 square 40x40 picture windows over the gable section of the house & replacing with 2-26x50 vertical casement windows & 1-40x18 horizontal sliding window.

Reason: the vertical casement windows will be used as egress windows. Evenly placed inside the bedroom. The horizontal slider is placed in the M. Bathroom above the tube for daylight, with privacy glass. The horizontal look was made so that the windows could be higher for privacy reasons.

2. **SOUTH ELEVATION (HOUSE SIDE):** Eliminating 1-50x68 french door, eliminating 1 square 40x40 picture window. & replacing with 3- 20x20 picture windows evenly placed alongside that south section of exterior wall.

Reason: The south elevation show 1 pair of french doors going into the master bedroom from the front porch, there is also another pair of french doors on the east elevation going into the living room/ kitchen area. With 2 french doors being placed on the entry porch, this would be confusing & cause a problem to anyone approaching the house to know which door to use. By placing 3 upper 20x20 Picture windows evenly on the south elevation under the porch area. The reason for the placement of the smaller windows is for a bit more privacy. For an Ext M. Bedroom wall to be up against a porch to go out to a front porch is a bit unorthodox. This way with the French door being eliminated & one bigger 40x40 window replaced by the 3-20x20 windows, gives the front entrance good curb & cemetery appeal & giving privacy to the M. Bedroom.

3. **EAST ELEVATION (Under Porch Side) –** Relocating the entry door to a proper area on the east exterior wall. Spreading out the existing 3-40x40 picture windows evenly on the east exterior wall.

Reason: The french doors that were placed on the E. Exterior wall did not functionally make sense to their size & placement of them. We repositioned the entry door North of the 3 picture windows & in lue of the french door, to put a single swing craftsman door with a transom above it. (Refer to color sheet A5.0)

- 4. WEST ELEVATION (ON ADU):** Adding a few windows on the 2nd floor & on the 1st floor for the ADU. Proposing 3 additional windows on the 2nd floor. 1 – 20x30 vertical Window & 2 – 20x20 picture windows. 1st floor to have 1 – 50x40 picture window right below.

Reason: This will bring more details to that wall section as well as give the rooms inside more daylight. The 2-20x20 pictures are in one of the bedrooms, the 1-20x30 window is in the upper bathroom, & 1-50x40 window is on the 1st floor in the garage.

- 5. NORTH ELEVATION (HOUSE SIDE):** Adding a 20x40 vertical window

Reason: Gives more Daylight into the restroom, Glass will be privacy glass.

B.ELEVATION & ESTHETIC CHANGES:

- 1. Garage Door:** Replacing the look of the garage door shown in the east elevation for the ADU. To a carriage style garage door with upper panel to be glass & grids. Also to have black hardware for the carriage bolts.

Reason: We wanted to bring more curb appeal to the building & with the garage door being closer to be viewed from Bidwell St this would make good details to the build. We also wanted to be tailored more towards the craftsman look & build with the other details on the home.

- 2. Roof Gable/Corbels/ & Bellyband:** Proposing to make the roof elevation a roof gable over the M. Bedroom in Lue of the hip & valley roof shown on the east elevation, on the main house.

Reason: The gable roof gives the house more details instead on just a shingle roof. This side can also be seen from Bidwell St & it would match the gable that is portrayed in the South Elevation of the ADU. There will be a 2x12 belly band separated the lap siding with the staggered shingles & corbels in each corner. This give the house a craftsman look instead of a ranch style roof shingle slope.

- 3. ADU 2nd Floor overhang & Details:** Proposing the 1st floor & 2nd floor have more detail than the south elevation shows. To have the 2nd floor cantilever 2ft over the first floor with a 2x12 belly band going around the perimeter of the bottom of the 2nd floor & installing corbels evenly spaced around the overhang on the south elevation & follow through to the east elevation.

Reason: By breaking up both floors, it gives the house more curb appeal & not so much mass of wall, that is facing Bidwell St. The South side of the ADU is the primary wall that is facing Bidwell St & we would like to make sure that it has plenty of curb appeal. The corbels underneath the overhand will give the ADU a nice clean craftsman feel. The belly band also breaks up that large piece of mass by getting a bit more color & separation into the mix. Also all 4 windows that will be facing Bidwell St will have shutters on them similar to the ones on the Elevation sheet & the Window Trim.

- 4. Window Trim: Detailing all the window trim to have more character instead of what the plans show with a 1x4 trim wrapped around. We will install a 1x4 trim on the vertical sides & a 1x6 on the top and bottom of the windows and a 1x2 apron on the bottom of the windows.**

Response: Trying to achieve all the features how a craftsman window wrap should actually & have it sync in with the remainder of the details on the house.

- 5. Exterior Colors: Changing from the existing colors, shown on sheet A3 on old plans, New Color Chart is shown on Sheet A5.0 on New plans**

Response:

- a. Older Colors**

Body- Melmac Silver,

Trim- Hammered Pewter,

Fascia, Doors, Shutters- Carbon

- b. New Colors**

Body: Blueberry

Trim: Cloud White

Gables: Leather Satchel

Conclusion:

The changes that we are applying or requesting for here today are not to eliminate any work, but on the contrary making the home look & feel as it belongs in the Historical Pocket.

Attachment 11

908 Bidwell Street Design Review, Variances, and Demolition Historic District Commission Staff Report, dated April 3, 2019



CITY OF
FOLSOM
DISTINCTIVE BY NATURE

Historic District Commission Staff Report

50 Natoma Street, Council Chambers

Folsom, CA 95630

Project: 908 Bidwell Street Residential Addition and Remodel
File #: PN-18-397
Request: Design Review, Variances, and Demolition
Location: 908 Bidwell Street
APN: 070-0201-010
Staff Contact: Steve Banks, Principal Planner, 916-461-6207
 sbanks@folsom.ca.us

Property Owner/Applicant

Name: Brian Martell
Address: 908 Bidwell Street
 Folsom, CA 95630

Recommendation: Conduct a public hearing and upon conclusion recommend approval of Design Review, Variances and Demolition for a 1,635-square-foot addition and remodel of an existing 1,202-square-foot single-family residence and demolition of a 120-square-foot rear portion of the main building and an 81-square-foot accessory structure as illustrated on Attachments 5 through 6 for the 908 Bidwell Street Residential Addition and Remodel project (PN 18-397) subject to the findings (Findings A-L) and conditions of approval (Conditions 1-23) attached to this report.

Project Summary: The proposed project involves a request for approval of Design Review, Variances, and Demolition for a 1,635-square-foot addition and remodel of an existing 1,202-square-foot single-family residence and demolition of an 81-square-foot accessory structure located at 908 Bidwell Street. Modifications to the existing residence include demolition of a 120-square-foot section of the rear portion of the house, a 423-square-foot addition to the main section of the house, a 350-square-foot front porch addition, a 606-square-foot attached garage addition, and a 606-square-foot attached second unit addition on top of the garage. The existing residence will also be remodeled to match the design, materials, and colors of the proposed residential additions.

The project also includes a request for approval of three separate Variances. The first Variance request is to allow the existing house to be located six-inches from the rear property line whereas a twenty-foot setback is required. As part of this Variance request, the project includes removal of a 120-square-foot section of the rear portion of the house, resulting in the rear wall plane of the house being shifted approximately two-feet,



six-inches to the south (the existing residence is currently situated two feet over the rear

property line). The second Variance request is to allow the proposed additions to the existing residence to be located two-feet from the left-side yard property line whereas a five-foot side yard setback is required. The third Variance request is to allow for development of a second unit on 5,500-square-foot residential lot whereas the minimum lot size required for development of a second unit on a residential lot is 6,000 square feet.

Table of Contents:

- 1 - Description/Analysis
- 2 - Background
- 3 - Conditions of Approval
- 4 - Vicinity Map
- 5 - Existing and Proposed Site Plan, dated September 17, 2018
- 6 - Building Elevations and Floor Plans, dated September 17, 2018
- 7 - Accessory Structure Evaluation Report, dated March 4, 2019
- 8 - Letter from Heritage Preservation League, dated February 13, 2019
- 9 - Site Photographs

Submitted,

A handwritten signature in blue ink, appearing to read "Pam Johns", with a long horizontal flourish extending to the right.

PAM JOHNS
Community Development Director

ATTACHMENT 1 DESCRIPTION/ANALYSIS

APPLICANT'S PROPOSAL

The applicant, Brian Martell, is requesting Design Review and Variances for a 1,635-square-foot addition and remodel of an existing 1,202-square-foot single-family residence and demolition of an 81-square-foot accessory structure located at 908 Bidwell Street. The proposed modifications to the existing single-family residence include elimination of a 120-square-foot section of the rear portion of the house, a 423-square-foot addition to the main section of the house, a 350-square-foot front porch addition, a 606-square-foot attached garage addition, and a 606-square-foot attached second unit addition on top of the garage. The existing residence will also be remodeled to match the design, materials, and colors of the proposed additions. Proposed building materials include horizontal lap siding, wood shingle siding, vinyl windows, wood doors, and architectural-grade composition roof shingles. The proposed color scheme features an earth tone primary color (Melmac Silver) supplemented with richer earth tone colors (Carbon and Hammered Pewter). Proposed site improvements include connection of underground utilities, construction of an asphalt driveway, placement of brick pavers in the breezeway, and installation of new irrigation and landscaping.

The proposed project also includes a request for approval of three Variances. The first Variance request is to permit the existing house to be located six-inches from the rear property line. The proposed project includes demolition of a 120-square-foot section of the rear portion of the house, resulting in the rear wall plane of the house being shifted approximately two-feet, six-inches to the south and off of the adjacent property. The impetus for demolishing the rear portion of the existing residence and shifting the wall plane back is that the owner of the subject property (Brian Martell) is under a court order to move the existing residence off of the adjacent property to the north. Mr. Martell has made numerous efforts to acquire the adjacent property to the north but has been unsuccessful.

The second Variance request is to permit the proposed building additions to the existing residence to be situated two-feet from the left-side yard property line. The existing residence is currently located two-feet from the left-side property line, the proposed additions would match this existing side yard setback distance. The third Variance request is to allow for development of a second unit on 5,500-square-foot residential lot. The minimum residential lot size required for development of a second units is currently 6,000 square feet.

POLICY/RULE

The Folsom Municipal Code (FMC Section 17.52.400) requires that all new structures and alterations to existing structures located within the Historic District obtain Design Review approval from the Historic District Commission. The Folsom Municipal Code (FMC Section 17.52.660) also states that demolition of a structure located in the Historic District is subject to review and approval by the Historic District Commission. Lastly, the Folsom Municipal Code (FMC Section 17.52.370) states that the Historic District Commission shall have final authority relating to an application for Variances from any provision of this title, within the boundaries of the Historic District.

ANALYSIS

General Plan and Zoning Consistency

The General Plan land use designation for the project site is SFHD (Single Family High Density) and the zoning designation for the project site is CEN/R-1-M (Central Subarea of the Historic Residential Primary Area/Single-Family Dwelling, Small Lot District). The Folsom Municipal Code (FMC, Section 17.52.540) indicates that single-family dwellings are a permitted use within the Central Subarea of the Historic Residential Primary Area. In addition, the Folsom Municipal Code (FMC, Section 17.52.500) states that second units are permitted within the Historic Residential Primary Area. The following table outlines the development standards that are applicable to the proposed project:

Development Standards Table		
	Required	Existing/Proposed
Minimum Lot Size	6,000 S.F.	5,500 S.F.
Minimum Lot Width	50 Feet	50 Feet
Required Front Yard Setback	20 Feet	20 Feet
Required Rear Yard Setback	20 Feet	6 Inches
Required Side Yard Setbacks	5 Feet each side	2 Feet and 7 Feet 9 Inches
Minimum Distance Between Structures	10 Feet	>10 Feet
Maximum Building Height	35 Feet	28 Feet
Minimum Parking Required	2 Parking Spaces	2 Parking Spaces
Minimum Pervious Surface	40%*	45%

* A residential lot containing a second unit may exceed the Subarea’s lot coverage requirement by 5%. In this particular case, the minimum pervious surface requirement for the Central Subarea is 45%.

As shown in the table above, the proposed project meets some of the applicable development standards including minimum lot width, required front yard setback, required right side yard setback, distance between structures, maximum building height, minimum parking, and minimum pervious surface. However, the proposed project does

not meet the applicable development standards relative to minimum lot size, required rear yard setback, and required left side yard setback. To address these non-conformities with the established development standards, the applicant is requesting approval of a series of Variances as discussed in the following section of this report.

Variances

As noted in the project summary section of this staff report, the proposed project includes a request for three separate Variances. The following is a detailed description of each of the specific Variance requests:

- **Rear Yard Setback Variance:**
The existing single-family residence is currently located approximately two-feet over the rear property line. The applicant is proposing to remove of a 120-square-foot section of the rear portion of the house, resulting in the rear wall plane of the house being shifted approximately two-feet, six-inches to the south. As a result, the applicant is requesting approval of a Variance to allow the existing house to be located six-inches from the rear property line whereas a twenty-foot rear yard setback is required (FMC, Section 17.52.540).
- **Side Yard Setback Variance:**
The existing single-family residence is currently located approximately two-feet from the left-side yard property line. The applicant is proposing to construct additions to the existing single-family residence that are also located two-feet from the left side yard property line. As a result, the applicant is requesting approval of a Variance to allow the proposed building additions to be located two-feet from the left side-yard property line whereas a five-foot side yard setback is required (FMC, Section 17.52.540).
- **Minimum Lot Size Variance:**
The existing single-family residence is located on a 5,500-square-foot lot or parcel. The applicant is proposing to construct a 1,635-square-foot addition to the existing single-family residence that includes an attached 606-square-foot second unit located above a garage. As a result, the applicant is requesting approval of a Variance to allow for development of a second unit on 5,500-square-foot residential lot whereas the minimum lot size required for development of a second unit on a residential lot is 6,000 square feet (FMC, Section 17.52.500).

In order to approve this request for a Variance(s), the Historic District Commission must find that there are special circumstances applicable to the property, including size, shape, topography, location or surroundings whereby the strict application of the zoning code deprives such property of privileges enjoyed by other property in the vicinity and under identical zoning classification. According to the Folsom Municipal Code (FMC, Section 17.62.040), the Commission may apply such conditions as it deems necessary to assure that the adjustment shall not constitute a grant of special privileges

inconsistent with the limitations upon other properties in the vicinity and zone in which such property is situated. The following are the specific statements (FMC, Section 17.62.020) that the Commission must consider in granting of a Variance:

1. That there are exceptional or extraordinary circumstances or conditions applying to the land, building or use referred to in the application, which circumstances or conditions do not apply generally to other land, buildings, and/or uses in the district;
2. That the granting of the application is necessary for the preservation and enjoyment of substantial property rights of the petitioner;
3. That the granting of such application will not, under the circumstances of the particular case, materially affect the health or safety of persons, residing or working in the neighborhood of the property of the applicant, and will not, under the circumstances of the particular case, be materially detrimental to the public welfare or injurious to property or improvements in the neighborhood.

In reviewing the proposed application, staff determined that there are special circumstances that apply to the subject property relative to lot size, lot dimensions, site access, and location of existing structures. In addition, staff determined that the proposed attached second unit will not be detrimental to surrounding properties. With regard to lot size, the subject parcel is only 5,500 square feet in size due to the presence of smaller 1,560-square-foot parcel (owned by another party) that is located between the subject property and the Persifer Street/Bidwell Street Alley. All of the residential lots on the 900 block of Bidwell Street, on which the subject property is located, are at least 7,000 square feet in size. In addition, a majority of residential lots located within the immediate project vicinity are 7,000 square feet in size or greater.

In terms of lot dimensions, the subject property is 110 feet in depth by 50 feet in width. A typical residential lot within this portion of the Central Subarea is 140 feet in depth by 50 feet in width. As noted in the previous discussion regarding lot size, there is another parcel between the subject property and the Persifer Street/Bidwell Street Alley, which accounts for subject property's substandard lot depth compared to other properties in the immediate project area.

In relation to site access, the subject property is only accessible from Bidwell Street due to the presence of another parcel between the subject property and the Persifer Street/Bidwell Street Alley. A typical residential lot within this portion of the Central Subarea has two points of access, one access point from a standard street (e.g. Bidwell Street) and another access point off of an alley (e.g. Persifer Street/Bidwell Street Alley).

With regard to the location of structures, the existing single-family residence is located two feet over the rear property line, two feet from the left-side property line, seven feet

nine inches from the right-side property line, and seventy-five feet from the front property line. The applicant is proposing to improve the existing situation by demolishing the back portion of existing residence so that the residence will now have a rear yard setback of six inches. There is an existing accessory building on the 1,560-square-foot parcel located behind the subject parcel. With demolition of the rear portion of the existing residence, there will be an eleven-foot separation between the subject residence and the accessory structure on the adjacent parcel (ten-foot separation required).

The applicant is also proposing to construct a residential addition to the existing residence that will be located two feet from the left-side property line, consistent with the left-side setback distance associated with the existing residence. It is important to note that the existing residence on the adjacent parcel to the west (910 Bidwell Street) has a right side yard setback of fourteen feet eight inches, thus there will be a sixteen-foot eight-inch separation between these two residential buildings (ten-foot separation required).

The proposed second unit was also evaluated relative to impacts on surrounding properties. As shown in the submitted plans, the proposed 606-square-foot second unit is located on top of a proposed 606-square-foot garage. The proposed second unit and garage are connected to the main residence by a fully covered breezeway, therefore, both the second unit and garage are considered part of the main residence. From an aesthetic perspective, the second unit features that same architectural design, building materials, and colors as proposed for the other portion of the single-family residence. As a result of the integrated design concept, the proposed second unit will not be easily discernible as a second dwelling unit.

Over the course of the past several years, there have been numerous second units constructed within the Historic District, most of which have been detached from the main residential structure. In fact, a detached second unit (on top of a garage) is currently under construction directly adjacent to the subject property at 910 Bidwell Street (Attachment 9). In addition to single-family residential uses (including second units), there are multi-family and commercial land uses in close proximity to the project site. In fact, a series of multi-family duplexes are located directly across Bidwell Street from the project site. Based on the existence of other second units in the immediate project area and the mixture of other intensive land uses in the project vicinity, staff has determined that the proposed attached second unit will not be detrimental to surrounding properties.

In summary, staff has determined that subject property's small lot size, substandard lot dimensions, limited site access, and location of existing structures represent a special circumstance or condition applicable to the property whereby the strict application of the zoning code deprives the property of privileges enjoyed by other properties within the vicinity under identical zoning classification. Staff has also determined that the granting of the subject Variance application is necessary for the preservation and enjoyment of

substantial property rights of the project application. Lastly, staff has determined that the granting of the subject Variance application will not, under the circumstances of this particular case, materially affect the health or safety of persons, residing or working in the neighborhood of the property of the applicant, and will not, under the circumstances of this particular case, be materially detrimental to the public welfare or injurious to property or improvements in the neighborhood.

Architecture/Design

As described previously within this report, the proposed project includes a 1,635-square-foot addition and remodel of an existing 1,202-square-foot single-family residence located at 908 Bidwell Street. The proposed residential addition includes a 606-square-foot attached second unit located on top of a proposed 606-foot attached garage. The Folsom Municipal Code (FMC, Section 17.105.040) states that if an application for a second dwelling unit complies with all of the requirements of Folsom Municipal Code, and the project does not present any adverse impacts on any real property that is listed in the California Register of Historic Places, such an application shall only be considered ministerially by Staff without discretionary review. In this particular case, the proposed second unit does not comply with all of the requirements of the Folsom Municipal Code (minimum lot size and side yard setback) as discussed within the Variance section of this staff report. As a result, the architecture and design of the entire project (including the attached second unit) is subject to review and approval by the Historic District Commission.

The proposed project, which is located within the Central Subarea of the Historic Residential Primary Area, is subject to the Historic District Design and Development Guidelines (Design Guidelines). The Design Guidelines provide guidance for implementation of the regulations imposed by Chapter 17.52 (Historic District) of the Folsom Municipal Code. The Design Guidelines also provide standards and procedures intended to assist in maintaining and recreating the 1850 to 1950 styles and patterns of development in the 98-block Historic District area.

The existing 1,202-square-foot single family residence (Attachment 9), which was constructed in 1952, features an architectural design is best characterized as Craftsman Style. The existing residence is not considered historically significant in terms of context, design, or building materials. The existing residence features horizontal wood siding, wood and aluminum-framed windows, wood-framed doors, a composition shingle roof, and a covered front porch. Proposed modifications to the existing residence include removing a 120-square-foot section of the back of the residence, replacing the existing horizontal lap siding with 4-inch horizontal hardiplank lap siding, eliminating three windows on the rear building elevation, adding two wood-framed windows on the north building elevation, replacing the remaining windows with wood-framed vinyl windows, replacing the existing doors with wood-framed French doors, replacing the existing composition shingle roofing with new architectural-grade composition roof shingles, and repainting the residence with an earth tone color scheme.

The proposed project also features a 1,635-square-foot addition to the existing single-family residence including a 423-square-foot addition to the main section of the house, a 350-square-foot front porch addition, a 606-square-foot attached garage addition, and a 606-square-foot attached second unit addition on top of the garage. The proposed addition will include the same design, materials, and colors utilized on the remodel of the existing residence with the addition of some minor enhancements. Additional enhancements include wood shutters, decorative gable vents, wood shingle siding, and a carriage-style garage door.

The Design Guidelines state that the goal of any remodeling project is to maintain or improve a structure's value to the owner and the community by achieving good design and historic appropriateness, to the greatest extent feasible. In evaluating a request to remodel a structure, the Design Guidelines indicate that the Historic District Commission shall consider the following factors:

1. The property owner's and community's benefit.
2. The structure's architectural and historical value.
3. Resources available for historic authenticity purposes, such as historical and architectural documentation, materials availability, and financing.

As noted previously within this staff report, the existing single-family residence features a Craftsman-Style design. Craftsman-style design is typically characterized by the use of prominent front porches, gable roof elements, decorative roof vents, horizontal wood siding, and wood-framed doors and windows. As shown in the submitted building elevations (Attachment 6), the proposed project incorporates a number of significant Craftsman-style design features including horizontal lap siding, wood shingle-siding, decorative roof vents, and wood-framed windows and doors.

The Design Guidelines for the Central Subarea include a number of recommendations relative to building materials including siding, trim, windows, doors, and roofing material. In terms of siding, the proposed project includes the use of 4-inch Hardiplank lap siding and Hardiplank wood shingles, both of which are considered acceptable materials according to the Design Guidelines. With regard to trim, the proposed project includes wood trim around all windows and doors as suggested by the Design Guidelines. However, as shown on the submitted plans (Attachment 6), the wood trim around the doors and windows is not being displayed or articulated in a particularly effective manner. To address this concern, staff recommends that enhanced wood trim be added around all doors and windows to the satisfaction of the Community Development Department.

The Design Guidelines indicate that wood-framed double-hung or casement windows are the preferred window type for the Central Subarea. However, the Design

Guidelines also state that vinyl-clad windows may be utilized for less historically significant structures. In general, window proportions should be vertical rather than horizontal; however, appropriate proportions and the number of window panes can vary depending on the style of the individual building. Regarding building entries, the Design Guidelines state that residentially-scaled and solid wood or glazed doors or many styles may be appropriate. The applicant is proposing to utilize a combination of vertically and horizontally-oriented vinyl-clad windows depending on the building elevations. The applicant is proposing to utilize two wood-framed French doors on the main portion of the residence and two single wood-framed doors for the second unit. Based on the fact that the existing residence is not particularly historic in appearance, staff is supportive of the proposed window and door design. However, staff recommends that the final design of the windows and doors is subject to review and approval by the Community Development Department.

The Design Guidelines state that appropriate roofing materials may include fireproof wood shingles, corrugated metal, composition fiberglass shingles, clay tile, or other materials as determined by historic evidence. Inappropriate roofing materials include colored standing seam metal roofs, glazed ceramic tile, and imitation roofing materials such as concrete shingles and imitation concrete mission tile. As recommended by the Design Guidelines, the proposed project includes the use of architectural-grade composition roof shingles.

In the Central Subarea of the Historic Residential Primary Area, the Design Guidelines suggest that garages identifiable as such are not allowed unless integral to the architectural time frame of the building's existing design. The Design Guidelines also recommend that garage doors be broken into smaller components to minimize their visual impact. Given that the project site has no access to the Persifer Street/Bidwell Street Alley and that the existing residence is already located at the rear boundary of the parcel, the applicant had limited options in terms of placement of the attached garage. To minimize the visual impact of the garage, the applicant has oriented the garage to face east so that it would be less visible from Bidwell Street. In addition, the applicant, created a residential design for the portion of the garage facing Bidwell Street so that the structure would not be easily identifiable as a garage. Lastly, the applicant created a carriage-style design for the garage door to create the appearance of two single garage doors as opposed to a two-car garage door. To further enhance the appearance of the garage door, staff recommends that door hinges, door handles, or similar design features be added to the satisfaction of the Community Development Department.

In reviewing the proposed project as shown on the submitted building elevations, staff determined that the proposed project will be of substantial benefit to the property owner and the community by maintaining an appropriate style of design (Craftsman) for the existing residence and addition while ensuring that they are maintained in good condition moving forward. In addition, staff has determined that the proposed project meets the intent of the Design Guidelines by maintaining an 1850 to 1950 appearance

standard through restoration and reconstruction of the residence in an authentic manner.

Staff forwards the following design recommendations to the Commission for consideration (Condition No. 16):

1. This approval is for a 1,635-square-foot addition and remodel of an existing 1,202-square-foot single-family residence for the 908 Bidwell Street Residential Addition and Remodel project. The applicant shall submit building plans that comply with this approval, the attached building elevations and attached floor plan, dated September 17, 2018.
2. The design, materials, and colors of the proposed 908 Bidwell Street Residential Addition and Remodel project shall be consistent with the submitted building elevations, material samples, and color scheme to the satisfaction of the Community Development Department.
3. Enhanced wood trim shall be added around all doors and windows to the satisfaction of the Community Development Department.
4. Door hinges, door handles, or similar design features shall be added to the garage door to the satisfaction of the Community Development Department.
5. The final design of the windows and doors shall be subject to review and approval by the Community Development Department.
6. The project driveway and driveway apron shall be constructed of an all-weather pervious treatment to the satisfaction of the Community Development Department.
7. Roof-mounted mechanical equipment, including satellite dish antennas, shall not extend above the height of the parapet walls. Ground-mounted mechanical equipment shall be shielded by landscaping or trellis type features.
8. All Conditions of Approval as outlined herein shall be made as a note or separate sheet on the Construction Drawings.

Parking

The Folsom Municipal Code (FMC, Section 17.52.540) requires single-family detached dwelling units are required to provide two on-site parking spaces. The parking spaces must be provided outside of required front and street side yards. The applicant is proposing two off-street parking spaces in a two-car side-load garage located adjacent to Bidwell Street. As a result, staff has determined that the proposal complies with the parking requirements established for the Central Subarea. It is important to note that there is no separate parking requirement for the attached second unit.

Project Driveway and Apron

As shown on the submitted site plan, the applicant is proposing to construct an asphalt driveway and driveway apron to provide access to the new garage. The Design Guidelines recommend that driveway improvements and other vehicular access requirements of new development be sensitive to the traditional if not historic character of the neighborhood and its existing features, and incorporate similar treatments. In general, the Design Guidelines state that accent pavements and oversized drives are not allowed within this context, although some scored concrete finishes may reflect the existing character of development. Given this guidance by the Design Guidelines, staff recommends that the project driveway and driveway apron be constructed of an all-weather pervious treatment to the satisfaction of the Community Development Department. Condition No. 16 is included to reflect this requirement.

Existing and Proposed Landscaping

Existing landscaping on the project site includes a combination of trees (Pine tree, Walnut tree, Fir tree, and ornamental fruit trees), shrubs, and groundcover. The applicant is proposing to remove approximately five trees for development of the proposed project, none of which is considered a protected tree according to the Folsom Municipal Code (FMC, Section 12.16). The applicant is proposing to preserve one large pine tree located adjacent to Bidwell Street. As shown on the submitted site (Attachment 5), the applicant is proposing to plant a new tree (Maple tree) and shrubs at various locations on the project site. Staff recommends that the owner/applicant submit a landscape and irrigation plan that is subject to review and approval by the Community Development Department. Condition No. 17 is included to reflect this requirement.

Garage/Shed Demolition

The applicant is proposing to demolish an 81-square-foot stone accessory structure located in the front yard of the subject property in order to accommodate development of the proposed residential addition and remodel project. In order to approve a request for demolition of a structure considered historically significant, the Folsom Municipal Code, (FMC Section 17.52.660) states that the Historic District Commission must consider the following:

1. Whether the public health, safety and/or welfare warrant the demolition;
2. What accommodations can be provided to the owner of the property to make it feasible for the owner to preserve the property;
3. Whether the owner of the property is willing to sell the property to a buyer who wishes to preserve the property; and
4. Whether a public entity wishes to acquire the property through exercise of the power of eminent domain in order to preserve the property.

Section 4.13 of the Historic District Design and Development Guidelines clarifies that demolition of structures with historic value should be approved only when all other options have been exhausted by the property owner and the City. However, Section 4.13 of the Design and Development Guidelines also makes clear that demolition may be more readily approved for structures which do not comply with the goals, policies, and regulations of the Folsom Municipal Code, (FMC Section 17.52) and the Design and Development Guidelines themselves.

The 81-square-foot stone accessory structure, which appears to have been constructed in 1965, features a concrete foundation, river rock cobble walls, a wooden door slat, and a wood shingle gabled roof. An evaluation of the accessory structure (Attachment 7) was completed by ECORP Consulting on March 4, 2019. The evaluation determined that the stone accessory structure appears to be a modern vernacular building constructed using modern construction techniques in 1965. In addition, the evaluation determined that the accessory structure is not associated with nearby Historic Folsom or any other historical associations related to mining or the early history of Folsom.

Heritage Preservation League Letter

The Heritage Preservation League (HPL) submitted a comment letter regarding the proposed project to City staff on February 13, 2010. In the letter, the HPL suggests that the project be entirely redesigned to meet all of the development standards established for the Central Subarea. In addition, the HPL recommends that a professional report regarding the potential significance of the stone accessory structure be prepared. As discussed within this staff report, staff determined that there are multiple special circumstances applicable to the subject property that support approval of Variances for development of the project as proposed. In addition, a professional evaluation indicating that the stone accessory structure is not historically significant has been provided with this report.

ENVIRONMENTAL REVIEW

The project is categorically exempt under Section 15301 Existing Facilities of the California Environmental Quality Act (CEQA) Guidelines.

RECOMMENDATION/HISTORIC DISTRICT COMMISSION ACTION

Move to Approve Design Review, Variances, and Demolition for a 1,635-square-foot addition and remodel of an existing 1,202-square-foot single-family residence and demolition of a 120-square-foot rear portion of the main building and an 81-square-foot accessory structure as illustrated on Attachments 5 through 6 for the 908 Bidwell Street Residential Addition and Remodel project (PN 18-397) subject to the findings (Findings A-L) and conditions of approval (Conditions 1-23) included as Attachment 3.

GENERAL FINDINGS

- A. NOTICE OF HEARING HAS BEEN GIVEN AT THE TIME AND IN THE MANNER REQUIRED BY STATE LAW AND CITY CODE.
- B. THE PROJECT IS CONSISTENT WITH THE GENERAL PLAN AND THE ZONING CODE OF THE CITY.

CEQA FINDINGS

- C. THE PROJECT IS CATEGORICALLY EXEMPT FROM ENVIRONMENTAL REVIEW UNDER SECTION 15301 (EXISTING FACILITIES) OF THE CALIFORNIA ENVIRONMENTAL QUALITY ACT (CEQA) GUIDELINES.
- D. THE CUMULATIVE IMPACT OF SUCCESSIVE PROJECTS OF THE SAME TYPE IN THE SAME PLACE, OVER TIME IS NOT SIGNIFICANT IN THIS CASE.
- E. NO UNUSUAL CIRCUMSTANCES EXIST TO DISTINGUISH THE PROPOSED PROJECT FROM OTHERS IN THE EXEMPT CLASS.
- F. THE PROPOSED PROJECT WILL NOT CAUSE A SUBSTANTIAL ADVERSE CHANGE IN THE SIGNIFICANCE OF A HISTORIC RESOURCE

DEMOLITION FINDING

- G. THE EXISTING SINGLE-FAMILY RESIDENCE (120-SQUARE-FOOT SECTION) AND STONE ACCESSORY STRUCTURE PROPOSED TO BE DEMOLISHED ARE NOT CONSIDERED HISTORICALLY SIGNIFICANT.

DESIGN REVIEW FINDINGS

- H. THE PROPOSED PROJECT COMPLIES WITH THE GENERAL PLAN AND ZONING ORDINANCES OF THE CITY.
- I. THE BUILDING MATERIALS, TEXTURES AND COLORS USED IN THE PROPOSED PROJECT ARE COMPATIBLE WITH SURROUNDING DEVELOPMENT AND ARE CONSISTENT WITH THE GENERAL DESIGN THEME OF THE NEIGHBORHOOD.
- J. THE PROPOSED PROJECT IS IN CONFORMANCE WITH THE HISTORIC DISTRICT DESIGN AND DEVELOPMENT GUIDELINES ADOPTED BY CITY COUNCIL.

VARIANCE FINDINGS

- K. THERE EXIST SPECIAL CIRCUMSTANCES APPLICABLE TO THE SUBJECT PROPERTY, INCLUDING SIZE AND SHAPE, THAT DO NOT APPLY GENERALLY TO OTHER PROPERTIES IN THE VICINITY THAT ARE UNDER THE IDENTICAL ZONING CLASSIFICATION.

- L. STRICT APPLICATION OF THE ZONING CODE WOULD DEPRIVE THE SUBJECT PROPERTY OF PRIVILEGES ENJOYED BY OTHER PROPERTIES IN THE VICINITY THAT ARE UNDER THE IDENTICAL ZONING CLASSIFICATION.

ATTACHMENT 2

BACKGROUND

BACKGROUND

The 1,202-square-foot single-family residence located on the subject property at 908 Bidwell Street was constructed in 1952. The existing residence, which features a concrete foundation, horizontal lap siding, wood/metal-framed doors and windows, and a composition shingle roof, is not considered historically significant in terms of building design and materials. The back portion (120 square feet) of the existing single-family residence is located approximately two-feet over the rear property line. The subject property owner (Brian Martell) is under a court order to move or remove the portion of the residence that is located on the adjacent parcel to the north. The project site also includes an 81-square-foot detached accessory structure (stone pumphouse) that was built around 1965 according to a report prepared for the project by ECORP Consulting (Attachment 7).

GENERAL PLAN DESIGNATION

SFHD (Single Family High Density)

ZONING

CEN/R-1-M (Central Subarea of the Historic Residential Primary Area/Single-Family Dwelling, Small Lot District)

ADJACENT LAND USES/ZONING

North: Single Family Residential Parcel (CEN/R-1-M) with the Persifer Street/Bidwell Street Alley Beyond

South: Bidwell Street with Multi-Family Residential Development (CEN/R-4) Beyond

East: Single-Family Residential Development (CEN/R-1-M) with Decatur Street Beyond

West: Single Family Residential Development (CEN/R-1-M) with Reading Street Beyond

SITE CHARACTERISTICS

The 0.13-acre project site is developed with a 1,202-square-foot single-family residence and an 81-square-foot accessory structure. Existing landscaping includes a combination of trees, shrubs, and grass.

APPLICABLE CODES

FMC Chapter 17.52 HD, Historic District

FMC Section 17.52.300, Design Review
FMC Section 17.52.540, Historic Residential
Primary Area Special Use and Design
Standards
FMC Section 17.52.660, Demolition
FMC Chapter 17.62 Variances
Historic District Design and Development
Guidelines (DDG's)

Attachment 3

Conditions of Approval

CONDITIONS OF APPROVAL FOR 908 BIDWELL STREET RESIDENTIAL ADDITION AND REMODEL PROJECT (PN 18-397)				
908 BIDWELL STREET				
DESIGN REVIEW AND VARIANCES				
	Mitigation Measure	Condition/Mitigation Measure	When Required	Responsible Department
1.		<p>The applicant shall submit final site development plans to the Community Development Department that shall substantially conform to the exhibits referenced below:</p> <ul style="list-style-type: none"> • Existing and Proposed Site Plan, dated September 17, 2018 • Building Elevations and Floor Plans, dated September 17, 2018 <p>This project approval is for the 908 Bidwell Street Residential Addition and Remodel project, which includes a 1,635-square-foot addition and remodel of an existing 1,202-square-foot single-family residence, demolition of a 120-square-foot rear portion of the existing single-family residence, and demolition of an 81-square-foot accessory structure located at 908 Bidwell Street. Implementation of the project shall be consistent with the above-referenced items as modified by these conditions of approval.</p>	B	CD (P)(E)
2.		Building plans shall be submitted to the Community Development Department for review and approval to ensure conformance with this approval and with relevant codes, policies, standards and other requirements of the City of Folsom.	B	CD (P)(E)(B)
3.		The project approvals granted under this staff report (Design Review and Variances) shall remain in effect for two years from final date of approval (April 3, 2021). Failure to obtain the relevant building (or other) permits within this time period, without the subsequent extension of this approval, shall result in the termination of this approval.	B	CD (P)

CONDITIONS OF APPROVAL FOR 908 BIDWELL STREET RESIDENTIAL ADDITION AND REMODEL PROJECT (PN 18-397)				
908 BIDWELL STREET				
DESIGN REVIEW AND VARIANCES				
	Mitigation Measure	Condition/Mitigation Measure	When Required	Responsible Department
4.		<p>The owner/applicant shall defend, indemnify, and hold harmless the City and its agents, officers and employees from any claim, action or proceeding against the City or its agents, officers or employees to attack, set aside, void, or annul any approval by the City or any of its agencies, departments, commissions, agents, officers, employees, or legislative body concerning the project. The City will promptly notify the owner/applicant of any such claim, action or proceeding, and will cooperate fully in the defense. The City may, within its unlimited discretion, participate in the defense of any such claim, action or proceeding if both of the following occur:</p> <ul style="list-style-type: none"> • The City bears its own attorney’s fees and costs; and • The City defends the claim, action or proceeding in good faith <p>The owner/applicant shall not be required to pay or perform any settlement of such claim, action or proceeding unless the settlement is approved by the owner/applicant.</p>	OG	CD (P)(E)(B) PW, PR, FD, PD, NS
DEVELOPMENT COSTS AND FEE REQUIREMENTS				
5.		The owner/applicant shall pay all applicable taxes, fees and charges at the rate and amount in effect at the time such taxes, fees and charges become due and payable.	B	CD (P)(E)
6.		If applicable, the owner/applicant shall pay off any existing assessments against the property, or file necessary segregation request and pay applicable fees.	B	CD (E)
7.		The City, at its sole discretion, may utilize the services of outside legal counsel to assist in the implementation of this project, including, but not limited to, drafting, reviewing and/or revising agreements and/or other documentation for the project. If the City utilizes the services of such outside legal counsel, the applicant shall reimburse the City for all outside legal fees and costs incurred by the City for such services. The applicant may be required, at the sole discretion of the City Attorney, to submit a deposit to the City for these services prior to initiation of the services. The applicant shall be responsible for reimbursement to the City for the services regardless of whether a deposit is required.	B	CD (P)(E)

CONDITIONS OF APPROVAL FOR 908 BIDWELL STREET RESIDENTIAL ADDITION AND REMODEL PROJECT (PN 18-397)				
908 BIDWELL STREET				
DESIGN REVIEW AND VARIANCES				
	Mitigation Measure	Condition/Mitigation Measure	When Required	Responsible Department
8.		If the City utilizes the services of consultants to prepare special studies or provide specialized design review or inspection services for the project, the applicant shall reimburse the City for actual costs it incurs in utilizing these services, including administrative costs for City personnel. A deposit for these services shall be provided prior to initiating review of the Final Map, improvement plans, or beginning inspection, whichever is applicable.	B	CD (P)(E)
9.		This project shall be subject to all City-wide development impact fees, unless exempt by previous agreement. This project shall be subject to all City-wide development impact fees in effect at such time that a building permit is issued. These fees may include, but are not limited to, fees for fire protection, park facilities, park equipment, Humbug-Willow Creek Parkway, Light Rail, TSM, capital facilities and traffic impacts. The 90-day protest period for all fees, dedications, reservations or other exactions imposed on this project will begin on the date of final approval (April 3, 2019). The fees shall be calculated at the fee rate in effect at the time of building permit issuance.	B	CD (P)(E), PW, PK
10.		The owner/applicant agrees to pay to the Folsom-Cordova Unified School District the maximum fee authorized by law for the construction and/or reconstruction of school facilities. The applicable fee shall be the fee established by the School District that is in effect at the time of the issuance of a building permit. Specifically, the owner/applicant agrees to pay any and all fees and charges and comply with any and all dedications or other requirements authorized under Section 17620 of the Education Code; Chapter 4.7 (commencing with Section 65970) of the Government Code; and Sections 65995, 65995.5 and 65995.7 of the Government Code.	B	CD (P)
11.		If applicable, the owner/applicant shall pay off any existing assessments against the property, or file necessary segregation request and pay applicable fees.	B	CD (E)
SITE DEVELOPMENT REQUIREMENTS				
12.		The improvement plans for the required private improvements shall be reviewed and approved by the Community Development Department prior to issuance of the Building Permit.	B	CD (E)

CONDITIONS OF APPROVAL FOR 908 BIDWELL STREET RESIDENTIAL ADDITION AND REMODEL PROJECT (PN 18-397)				
908 BIDWELL STREET				
DESIGN REVIEW AND VARIANCES				
	Mitigation Measure	Condition/Mitigation Measure	When Required	Responsible Department
13.		The owner/applicant shall coordinate the planning, development and completion of this project with the various utility agencies (i.e., SMUD, PG&E, etc.).	I	CD (P)(E)
14.		The owner/applicant shall obtain a Demolition Permit prior to demolition of the 120-square-foot rear portion of the existing single-family residence and 81-square-foot stone accessory structure located in front of the single-family residence. In addition, compliance with all local, state and federal regulations pertaining to demolition of the garage/shed structure is required.	I, B	CD (E), B
STORM WATER POLLUTION/CLEAN WATER ACT REQUIREMENTS				
15.		During Construction, the owner/applicant shall be responsible for litter control and sweeping of all paved surfaces in accordance with City standards. All on-site storm drains shall be cleaned immediately before the commencement of the rainy season (October 15).	G, I, B	CD (E)

ARCHITECTURE/SITE DESIGN REQUIREMENTS				
16.		<p>The project shall comply with the following architecture and design requirements:</p> <ol style="list-style-type: none"> 1. This approval is for a 1,635-square-foot addition and remodel of an existing 1,202-square-foot single-family residence for the 908 Bidwell Street Residential Addition and Remodel project. The applicant shall submit building plans that comply with this approval, the attached building elevations and attached floor plan, dated September 17, 2018. 2. The design, materials, and colors of the proposed 908 Bidwell Street Residential Addition and Remodel project shall be consistent with the submitted building elevations, material samples, and color scheme to the satisfaction of the Community Development Department. 3. Enhanced wood trim shall be added around all doors and windows to the satisfaction of the Community Development Department. 4. Door hinges, door handles, or similar design features shall be added to the garage door to the satisfaction of the Community Development Department. 5. The final design of the windows and doors shall be subject to review and approval by the Community Development Department. 6. The project driveway and driveway apron shall be constructed of an all-weather pervious treatment to the satisfaction of the Community Development Department. 7. Roof-mounted mechanical equipment, including satellite dish antennas, shall not extend above the height of the parapet walls. Ground-mounted mechanical equipment shall be shielded by landscaping or trellis type features. 8. All Conditions of Approval as outlined herein shall be made as a note or separate sheet on the Construction Drawings. 	B	CD (P) (B)

16. Cont.		<p>9. <u>The two-story building elevation directly facing Bidwell Street (southern building elevation) shall be enhanced with new architectural and design elements to the satisfaction of the Community Development Department (this condition was added by the Historic District Commission at its April 3, 2019 meeting).</u></p> <p>10. <u>The owner/applicant shall submit a color and materials board that is subject to review and approval by the Community Development Department (this condition was added by the Historic District Commission at its April 3, 2019 meeting).</u></p>	B	CD (P) (B)
LANDSCAPE/TREE PRESERVATION REQUIREMENTS				
17.		<p>Pursuant to the state’s Model Water Efficient Landscape Ordinance (MWELo), all new construction projects with an aggregate front yard landscape area equal to or greater than 500 square feet shall submit a landscape documentation package and landscape permit application to the CDD for review and approval. The landscape permit shall be issued prior to, or at the time of, the issuance of a building permit.</p> <p>Projects with an aggregate front yard landscape area of 500 to 2,500 square feet may either:</p> <p>a) Comply with the performance requirements of the MWELo and within 24 months of the date of landscape permit issuance shall install the City-approved landscape and submit a Certificate of Completion to the CDD; or</p> <p>b) Comply with the simpler Prescriptive Compliance Option contained in Appendix D to the MWELo and, by the time of final inspection for a Building Permit for the custom home, shall install the City-approved landscape and submit a Certificate of Completion to the CDD.</p> <p>Projects with an aggregate front yard landscape area of more than 2,500 square feet shall comply with the performance requirements of the MWELo and within 24 months of the date of landscape permit issuance shall install the City-approved landscape and submit a Certificate of Completion to the CDD.</p>	I	CD (P)(E)

17. Cont.		<p>Projects with an aggregate front yard landscape area of less than 500 square feet shall submit a preliminary landscape plan to the CDD for review and approval prior to, or at the time of, the issuance of a building permit. The preliminary landscape plan shall show all proposed front yard landscaping with irrigated planting areas, plant materials, street tree species and location, footprints of buildings or structures, sidewalks, driveways, decks, patios, gravel or stone walks, or other pervious or non-pervious hardscapes, and other non-irrigated areas designated for non-development (such as open spaces and existing native vegetation). The preliminary landscape plan shall also include the calculation of front yard landscape area consistent with the definition herein. The City-approved landscaping shall be installed within 24 months of the date of building permit issuance.</p> <p>Any significant modification to the City-approved landscaping shall comply with the State’s Model Water Efficient Landscape Ordinance.</p> <p>For purposes of this condition of approval, “landscape area” means all the irrigated planting areas, irrigated turf areas, and water features in a landscape design plan or preliminary landscape plan. The landscape area does not include footprints of buildings or structures, sidewalks, driveways, parking lots, decks, patios, gravel or stone walks, other pervious or non-pervious hardscapes, and other non-irrigated areas designated for non-development (e.g., open spaces and existing native vegetation).</p>	I	CD (P)(E)
NOISE REQUIREMENT				
18.		<p>Compliance with Noise Control Ordinance and General Plan Noise Element shall be required. Hours of construction operation shall be limited from 7:00 a.m. to 6:00 p.m. on weekdays and 8:00 a.m. to 5:00 p.m. on Saturdays. No construction is permitted on Sundays or holidays. In addition, construction equipment shall be muffled and shrouded to minimize noise levels.</p>	I, B	CD (P)(E)

CULTURAL RESOURCE REQUIREMENTS				
19.		If any archaeological, cultural, or historical resources or artifacts, or other features are discovered during the course of construction anywhere on the project site, work shall be suspended in that location until a qualified professional archaeologist assesses the significance of the discovery and provides consultation with the Folsom Historical Society, City staff, and the Heritage Preservation League. Appropriate mitigation as recommended by the archaeologist and the Historical Society representative shall be implemented. If agreement cannot be met, the Historic District Commission shall determine the appropriate implementation method.	G, I, B	CD (P)(E)(B)
20.		In the event human remains are discovered, California Health and Safety Code Section 7050.5 states that no further disturbance shall occur until the county coroner has made the necessary findings as to the origin and disposition pursuant to Public Resources Code 5097.98. If the coroner determines that no investigation of the cause of death is required and if the remains are of Native American Origin, the coroner will notify the Native American Heritage Commission, which in turn will inform a most likely decedent. The decedent will then recommend to the landowner or landowner's representative appropriate disposition of the remains and any grave goods.	G, I, B	CD (P)(E)(B)
21.		Discovery of unknown contaminated soils during construction. If during construction, currently unknown contaminated soils are discovered (i.e., discolored soils, odorous, other indications), construction within the area shall be halted, the extent and type of contamination shall be characterized, and a clean-up plan shall be prepared and executed. The plan shall require remediation of contaminated soils. The plan shall be subject to the review and approval of SCEMD, RWQCB, the City of Folsom, or other agencies, as appropriate. Remediation can include in-situ treatment, disposal at an approved landfill, or other disposal methods, as approved. Construction can proceed within the subject area upon approval of and in accordance with the plan.	G, I, B	CD (P)(E)(B)
OTHER AGENCY REQUIREMENTS				
22.		The owner/applicant shall obtain all required State and Federal permits and provide evidence that said permits have been obtained, or that the permit is not required, subject to staff review and approval of any grading or improvement plan.	I, G	CD (P)(E)
23.		The owner/applicant shall obtain permission (permit, letter, agreement, etc.) from all applicable public utility companies (SMUD, PG&E, WAPA, etc.) in a form acceptable to the Community Development Department for construction-related activities proposed within the existing public utility easements.	I	CD (P)

CONDITIONS

See attached tables of conditions for which the following legend applies.

RESPONSIBLE DEPARTMENT		WHEN REQUIRED	
CD	Community Development Department	I	Prior to approval of Improvement Plans
(P)	Planning Division	M	Prior to approval of Final Map
(E)	Engineering Division	B	Prior to issuance of first Building Permit
(B)	Building Division	O	Prior to approval of Occupancy Permit
(F)	Fire Division	G	Prior to issuance of Grading Permit
PW	Public Works Department	DC	During construction
PR	Park and Recreation Department	OG	On-going requirement
PD	Police Department		

Attachment 12

Minutes from April 3, 2019 Historic District Commission Meeting



CITY OF
FOLSOM
CALIFORNIA

HISTORIC DISTRICT COMMISSION MINUTES
April 3, 2019
CITY COUNCIL CHAMBERS
5:00 p.m.
50 Natoma Street
Folsom, California 95630

CALL TO ORDER HISTORIC DISTRICT COMMISSION: Rosario Rodriguez, Vice Chair Candy Miller, Mickey Ankhelyi, Daniel West, Kevin Duewel, Mary Asay, Chair Daron Bracht

ABSENT: Miller

PLEDGE OF ALLEGIANCE

CITIZEN COMMUNICATION: None

MINUTES: The minutes of March 6, 2019 were approved as submitted.

NEW BUSINESS

1. **PN 18-397, 908 Bidwell Street Residential Addition, Remodel, Demolition, Variances and Determination that the Project is Exempt from CEQA**

A Public Hearing to consider a request from Brian Martell for Design Review approval and Variances for rear and side yard setbacks and minimum lot size, for a 1,635-square-foot addition and remodel of an existing 1,202-square-foot single-family residence and demolition of a 120-square-foot rear portion of the main structure and an 81-square-foot accessory structure located at 908 Bidwell Street. The zoning classification for the site is CEN/R-1-M and the General Plan land-use designation is SFHD. The project is categorically exempt under Section 15301 Existing Facilities of the California Environmental Quality Act (CEQA) Guidelines. (Project Planner: Principal Planner, Steve Banks / Applicant: Brian Martell)

1. Paul Keast addressed the Historic District Commission, citing concerns that the project would create greater density and parking issues.
2. Paul Kerfeld addressed the Historic District Commission, citing concerns about the projects variances and addition location.
3. Paul Reid addressed the Historic District Commission, citing that the project satisfies the encroachment lawsuit and beautifies a home that is run down.
4. Jennifer Lane addressed the Historic District Commission, citing concerns about second unit dwellings in the Historic District.
5. Cindy Pharis addressed the Historic District Commission, citing concerns about the project following the Historic District Guidelines and the variances.

Historic District Commission
April 3, 2019
Page 1 of 2

COMMISSIONER RODRIGUEZ MOVED TO APPROVE DESIGN REVIEW, VARIANCES, AND DEMOLITION FOR A 1,635-SQUARE-FOOT ADDITION AND REMODEL OF AN EXISTING 1,202-SQUARE-FOOT SINGLE-FAMILY RESIDENCE AND DEMOLITION OF A 120-SQUARE-FOOT REAR PORTION OF THE MAIN BUILDING AND AN 81-SQUARE-FOOT ACCESSORY STRUCTURE AS ILLUSTRATED ON ATTACHMENTS 5 THROUGH 6 FOR THE 908 BIDWELL STREET RESIDENTIAL ADDITION AND REMODEL PROJECT (18-397) SUBJECT TO THE FOLLOWING FINDINGS: GENERAL FINDINGS A & B, CEQA FINDINGS C-F, DEMOLITION FINDING G, DESIGN REVIEW FINDING H – J, VARIANCE FINDINGS K & L, AND CONDITIONS OF APPROVAL NO. 1-23.

COMMISSIONER ASAY SECONDED THE MOTION WHICH CARRIED THE FOLLOWING VOTE:

AYES: RODRIGUEZ, WEST, ASAY
NOES: ANKHELYI, DUEWEL
ABSTAIN: BRACHT
ABSENT: MILLER

PRINCIPAL PLANNER REPORT

None

There being no further business, the meeting was adjourned at 6:45pm.

Respectfully Submitted,



Kelly Mullett, SENIOR OFFICE ASSISTANT

APPROVED:



Daron Bracht, CHAIR

Attachment 13

Site Photographs







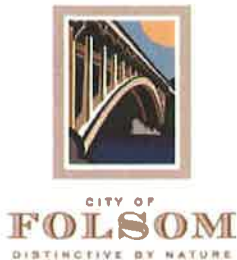

Historic District Commission Staff Report

50 Natoma Street, Council Chambers
Folsom, CA 95630

Project: 813 Natoma Street Addition
File #: PN 21-058
Request: Design Review
Location: 813 Natoma Street
Parcel(s): 070-0154-002
Staff Contact: Josh Kinkade, Associate Planner, 916-461-6209
jkinkade@folsom.ca.us

Property Owner/Applicant

Name: Eric Winokur
Address: 813 Natoma St.
Folsom, CA 95630

Recommendation Conduct a public meeting, and upon conclusion recommend approval of an application for Design Review for a 291-square-foot addition to an existing single-family residence located at 813 Natoma Street, as illustrated on Attachment 5 for the 813 Natoma Street Addition project (PN 21-058) subject to the findings included in this report (Findings A-H) and attached conditions of approval (Conditions 1-8).

Project Summary: The proposed project consists of a 291-square foot addition to the rear of an existing 1,217-square-foot single-family residence located at 813 Natoma Street. The property is located within the Central Subarea of the Historic Residential Primary Area of the Historic District.

Table of Contents:

- 1 - Description/Analysis
- 2 - Background
- 3 - Proposed Conditions of Approval
- 4 - Vicinity Map
- 5 - Site Plan dated 12-6-20, Floor Plans, Elevations and Rendering dated 3-22-21
- 6 - Site Photos
- 7 - PowerPoint Presentation



CITY OF
FOLSOM
DISTINCTIVE BY NATURE

AGENDA ITEM NO. 2
Type: Public Meeting
Date: April 21, 2021

Submitted,

PAM JOHNS
Community Development Director

**ATTACHMENT 1
DESCRIPTION/ANALYSIS**

APPLICANT'S PROPOSAL

The applicant, Eric Winokur, is proposing a 291-square foot addition to the rear of an existing 1,217-square-foot single-family residence located at 813 Natoma Street. Exterior colors, materials, roofing and window trim of the addition are proposed to match those of the existing residence.

POLICY/RULE

Section 17.52.300 of the Folsom Municipal Code (FMC) states that the Historic District Commission shall have final authority relating to the design and architecture of all exterior renovations, remodeling, modification, addition or demolition of existing structures within the Historic District. Section 17.52.330 states that, in reviewing projects, the Commission shall consider the following criteria:

- a) Project compliance with the General Plan and any applicable zoning ordinances;
- b) Conformance with any city-wide design guidelines and historic district design and development guidelines adopted by the city council;
- c) Conformance with any project-specific design standards approved through the planned development permit process or similar review process; and
- d) Compatibility of building materials, textures and colors with surrounding development and consistency with the general design theme of the neighborhood.

ANALYSIS

General Plan and Zoning Consistency

The General Plan land use designation for the project site is SFHD (Single-Family High Density), and the zoning designation for the project site is R-1-M (Single-Family Residential, Small Lot), within the Central Subarea of the Historic Residential Primary Area of the Historic District. Single-family residences are allowed by right in the Central Subarea.

Section 17.52.540 of the Folsom Municipal Code institutes requirements for lot size, lot width, setbacks, pervious surface, and building height in the Historic Residential Primary Area. The design standards established within the Historic District Design and Development Guidelines (DDGs) also apply to this project. The following table shows how the proposed project relates to the FMC zoning requirements:

	REQUIRED	PROPOSED
Minimum Lot Size	7,000 SF	7,000 SF (existing)
Minimum Lot Width	50 Feet	50 Feet (existing)
Front Setback	20 Feet	18 Feet (existing)
Rear Setback	20 Feet	59.2 Feet (proposed)
Side Setback	5 Feet (Interior)	7.88 Feet and 7.88 Feet (existing and proposed)
Minimum Pervious Surface	45%	64% (proposed)
Parking Requirement	2 Parking Spaces	2 Parking Spaces (existing)
Maximum Building Height	35 Feet	16.6 Feet (existing)
Structure Separation	10 Feet	>10 Feet

As shown in the above table (and on the site plan in Attachment 5), the existing structure currently sits 2 feet into the required 20-foot front yard setback. The existing structure is considered existing non-conforming to the front setback, but because the structure was legally constructed in 1957, prior to the setback standards being in-place, it is legally non-conforming and may therefore continue in its current condition per FMC Section 17.52.690(B). If this project is approved, the applicant would not be increasing the non-conformity, as the proposed modifications will not expand the footprint of the building within the non-conforming setback area. Finally, staff has provided Condition No. 7, which ensures that all existing walls located within current setbacks remain standing during construction activities, and that if any exterior walls not conforming to current setbacks are torn down during construction that they be replaced by walls that meet current setbacks, subject to approval by the Historic District Commission.

Building Design/Architecture

The property is located within the Central Subarea of the Historic Residential Primary Area of the Historic District. Chapter 5.04.03(b) of the DDGs, which addresses the design concepts for the Central Subarea, states that the Central Subarea provides property owners with broad discretion in choosing styles from the entire 1850-1950 timeframe. Restoration, reconstruction, and new construction of "average" homes are encouraged, rather than increase in the number of "high-style" homes. The design, color, and scale of the proposed residence are consistent with the architectural styles prevalent during the 1850-1950 timeframe in the Subarea. Furthermore, in assessing the appropriateness of a particular use/design, the DDGs recommend that consideration be given to the physical circumstances of the project site and its surroundings in the Central Subarea.

The property at 813 Natoma Street is not included on the City of Folsom Cultural Resources Inventory.

The DDG's state that exterior materials and finishes should be of residential grade, durable and of high quality and should include details appropriate for design period of

the Subarea and building style. The proposed project consists of a 291-square-foot addition that matches the siding, colors, roofing and window trim of the existing residence. The roofline of the existing residence is proposed to continue with the addition. The addition includes vertically-oriented windows, and residentially-scaled doors on the right and rear elevations, consistent with the DDGs,

Staff has determined that the overall design, colors, materials, and layout of the proposed addition are consistent with the design and development guidelines for the Central Subarea and the building materials, textures and colors are consistent with surrounding development and with the general design theme of the neighborhood. Staff has concluded that the applicant has met the design standards identified in the Folsom Municipal Code and the guidelines contained in the DDG's.

PUBLIC NOTICING COMMENTS

A notice was posted on the project site five days prior to the Historic District Commission meeting of April 21, 2021 that meets the requirements of FMC Section 17.52.320.

ENVIRONMENTAL REVIEW

The project is categorically exempt under Section 15301 (Existing Facilities) of the California Environmental Quality Act (CEQA) Guidelines. Based on staff's analysis of this project, none of the exceptions in Section 15300.2 of the CEQA Guidelines apply to the use of the categorical exemption in this case.

RECOMMENDATION/HISTORIC DISTRICT COMMISSION ACTION

Staff recommends approval of the proposed project, subject to the findings included in this report (Findings A-H) and the attached conditions of approval (Conditions 1-8).

Move to approve the Design Review application (PN 21-058) for a 291-square-foot addition to an existing single-family residence located at 813 Natoma Street, as illustrated on Attachment 5 for the 813 Natoma Street Addition project, subject to the findings included in this report (Findings A-H) and attached conditions of approval (Conditions 1-8).

GENERAL FINDINGS

- A. NOTICE OF PUBLIC MEETING HAS BEEN GIVEN AT THE TIME AND IN THE MANNER REQUIRED BY STATE LAW AND CITY CODE.
- B. THE PROJECT IS CONSISTENT WITH THE GENERAL PLAN AND ZONING CODE OF THE CITY.

CEQA FINDINGS

- C. THE PROJECT IS CATEGORICALLY EXEMPT FROM ENVIRONMENTAL REVIEW UNDER SECTION 15301 (EXISTING FACILITIES) OF THE CALIFORNIA ENVIRONMENTAL QUALITY ACT (CEQA) GUIDELINES.
- D. THE CUMULATIVE IMPACT OF SUCCESSIVE PROJECTS OF THE SAME TYPE IN THE SAME PLACE, OVER TIME IS NOT SIGNIFICANT IN THIS CASE.
- E. NO UNUSUAL CIRCUMSTANCES EXIST TO DISTINGUISH THE PROPOSED PROJECT FROM OTHERS IN THE EXEMPT CLASS.
- F. THE PROPOSED PROJECT WILL NOT CAUSE A SUBSTANTIAL ADVERSE CHANGE IN THE SIGNIFICANCE OF A HISTORICAL RESOURCE.

DESIGN REVIEW FINDINGS

- G. THE BUILDING MATERIALS, TEXTURES AND COLORS USED IN THE PROPOSED PROJECT ARE COMPATIBLE WITH SURROUNDING DEVELOPMENT AND ARE CONSISTENT WITH THE GENERAL DESIGN THEME OF THE NEIGHBORHOOD.
- H. THE PROPOSED PROJECT IS IN CONFORMANCE WITH THE HISTORIC DISTRICT DESIGN AND DEVELOPMENT GUIDELINES ADOPTED BY CITY COUNCIL.

**ATTACHMENT 2
BACKGROUND**

BACKGROUND

Sacramento County records indicate that the existing 1,217-square-foot single-family residence located at 813 Natoma Street was first constructed in 1957. The building features green horizontal lap siding, beige window trim and brown asphalt shingle roofing and a covered front porch. Photographs of the existing residence are included here as Attachment 6. The property does not appear on the City of Folsom's Cultural Resources Inventory.

GENERAL PLAN DESIGNATION

SFHD, Single-Family High-Density

ZONING

CEN, Central Subarea of the Historic Residential Primary Area, with an underlying zoning of R-1-M (Single-Family Residential-Small Lot)

ADJACENT LAND USES/ZONING

North: Natoma Street alley with residences beyond (CEN)
South: Natoma-Persifer Street alley with residences beyond (CEN)
East: Existing residences (CEN)
West: Existing residence (CEN) and Decatur Street beyond

SITE CHARACTERISTICS

The 7,000-square-foot project site contains an existing single-family residence, detached garage, paving and landscaping.

APPLICABLE CODES

FMC Chapter 17.52 HD, Historic District
FMC Section 17.52.300, Design Review
FMC Section 17.52.330, Plan Evaluation
FMC Section 17.52.340, Approval Process
FMC Section 17.52.540, Historic Residential Primary Area Special Use and Design Standards
Historic District Design and Development Guidelines

ATTACHMENT 3
Proposed Conditions of Approval

CONDITIONS OF APPROVAL FOR 813 NATOMA STREET ADDITION DESIGN REVIEW (PN 21-058)				
Cond. No.	Mitigation Measure	GENERAL REQUIREMENTS	When Required	Responsible Department
1.		Issuance of a Building Permit is required. The applicant shall submit final site and building plans to the Community Development Department that substantially conform to the site plan dated 12-6-20 and floor plans and elevations dated 3-22-21, included in Attachment 5. Implementation of this project shall be consistent with the above referenced items as modified by these conditions of approval.	B	CD (B)
2.		Compliance with all local, state and federal regulations pertaining to building construction and demolition is required.	OG	CD (B)
3.		This approval is for a 291-square-foot addition to an existing 1,217-square-foot single-family residence located at 813 Natoma Street. The applicant shall submit building plans that comply with this approval and the site plan dated 12-6-20, and floor plans and building elevations dated 3-22-21 included in Attachment 5.	B	CD (P)
4.		If any archaeological, cultural, or historical resources or artifacts, or other features are discovered during the course of construction anywhere on the project site, work shall be suspended in that location until a qualified professional archaeologist assesses the significance of the discovery and provides recommendations to the City. The City shall determine and require implementation of the appropriate mitigation as recommended by the consulting archaeologist. The City may also consult with individuals that meet the Secretary of the Interior's Professional Qualifications Standards before implementation of any recommendation. If agreement cannot be reached between the project applicant and the City, the Historic District Commission shall determine the appropriate implementation method.	G, I, B	CD (P)(E)(B)
5.		In the event human remains are discovered, California Health and Safety Code Section 7050.5 states that no further disturbance shall occur until the county coroner has made the necessary findings as to the origin and disposition pursuant to Public Resources Code 5097.98. If the coroner determines that no investigation of the cause of death is required and if the remains are of Native American Origin, the coroner will notify the Native American Heritage Commission, which in turn will inform a most likely decedent. The decedent will then recommend to the landowner or landowner's representative appropriate disposition of the remains and any grave goods.	G, I, B	CD (P)(E)(B)
6.		All exterior walls on portions of the existing structure within current front yard setbacks shall remain standing for the duration of project construction activities. If existing exterior walls located within a current setback are removed at any point during construction, new construction and/or reconstruction of those walls shall meet current setbacks and will be subject to approval by the Historic District Commission.	DC	CD (P) (B)

7.		Per <u>FMC</u> Section 12.16.190 (Street Tree Planting), applicants for a building permit for new construction of residential or commercial structures on parcels without existing street trees, or planned development permit which seeks, in whole or in part, the improvement of real property, shall be responsible for the planting of street trees. There shall be at least one street tree for each single-family and two-family lot, except for corner lots, for which two trees shall be planted. As part of the application process, the city arborist shall review and approve the species and size of the tree to be planted and the location of the planting. All street trees shall be planted at the time of the final inspection, prior to occupancy.	O	CD (E)
8.		The project approval granted under this staff report shall remain in effect for one year from final date of approval (April 21, 2022). Failure to obtain the relevant building, demolition, or other permits within this time period, without the timely extension of this approval, shall result in the termination of this approval.	B	CD (P)

RESPONSIBLE DEPARTMENT		WHEN REQUIRED	
CD (P) (E) (B) (F)	Community Development Department Planning Division Engineering Division Building Division Fire Division	I	Prior to approval of Improvement Plans
		M	Prior to approval of Final Map
		B	Prior to issuance of first Building Permit
		O	Prior to approval of Occupancy Permit
		G	Prior to issuance of Grading Permit
PW	Public Works Department	DC	During construction
PR	Park and Recreation Department	OG	On-going requirement
PD	Police Department		

Attachment 4 Vicinity Map

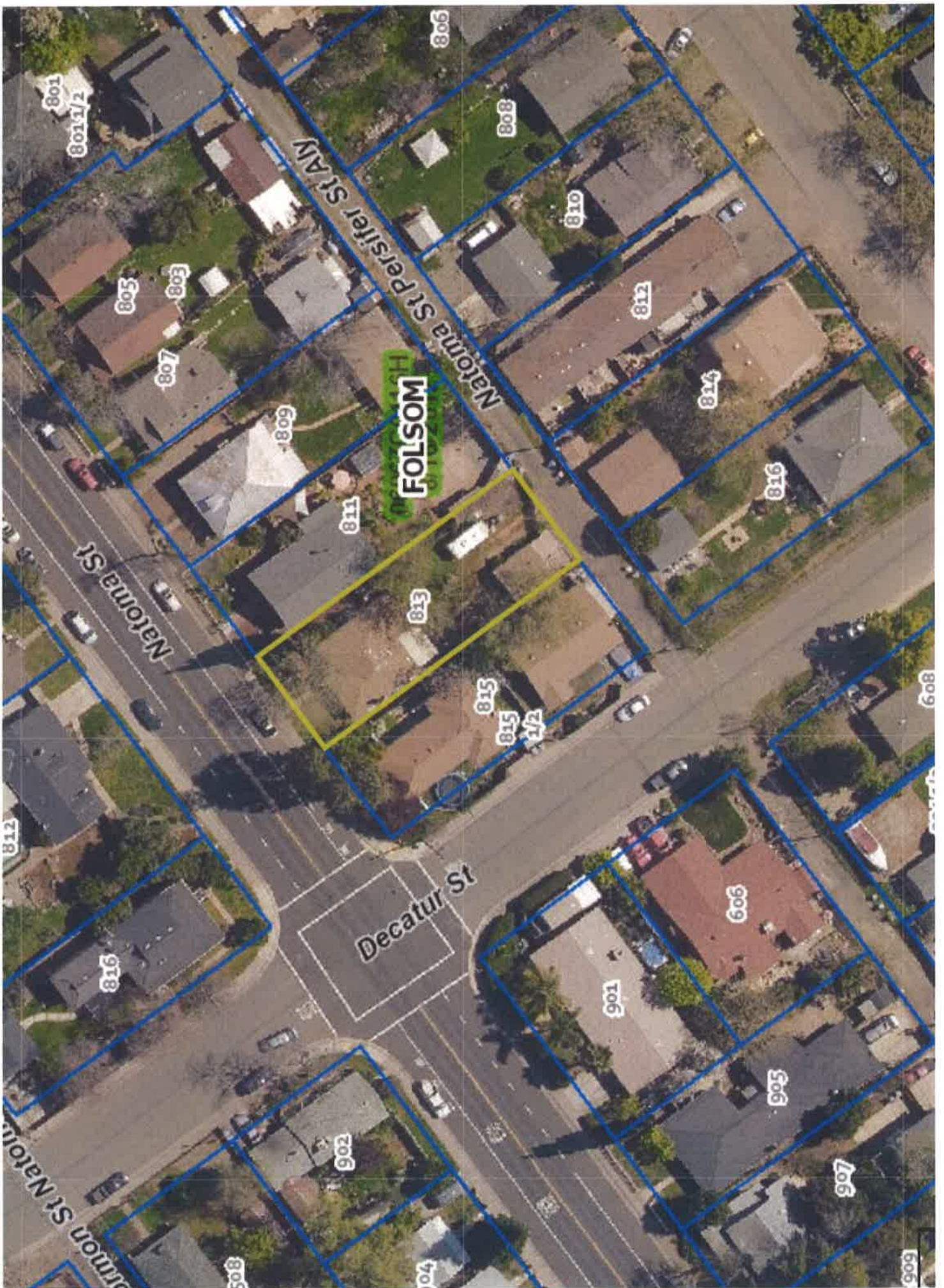

Historic District Commission
813 Natoma Street Addition Design Review (PN 21-058)
April 21, 2021

Attachment 5
Site Plan Dated 12-6-20, Floor Plans, Elevations
and Rendering dated 3-22-21

Eric Winokur

ADDITION FOR:
 MR. ERIC WINOKUR
 (408) 921-4207

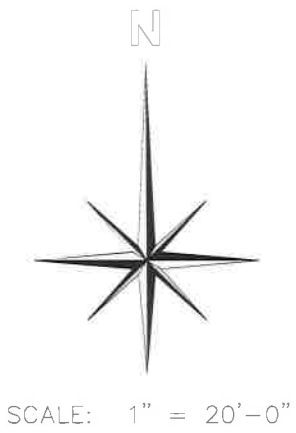
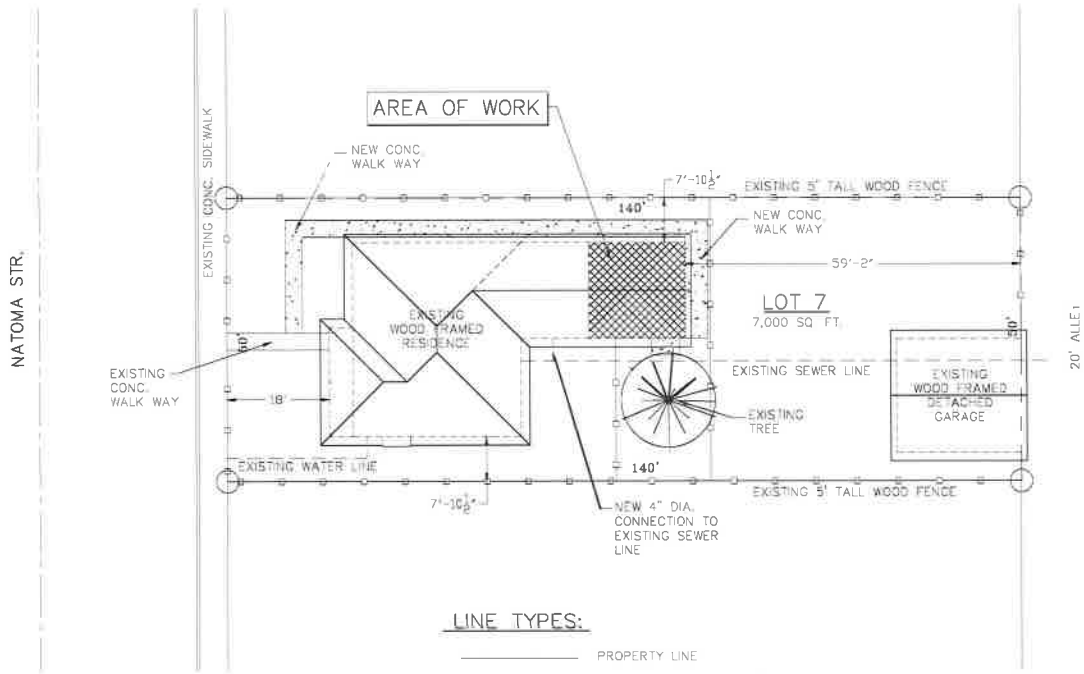

- LINE TYPES:**
- PROPERTY LINE
 - NEW FENCE LINE (U.N.O.)
 - - - UTILITY LINE
 - - - OUTLINE OF HOUSE

813 NATOMA STREET
 FOLSOM, CA. 95630-3012
 LOT 7, BLOCK 77

SITE PLAN
 SCALE: 1" = 20'-0"

CITY OF FOLSOM
 BK. 70-PG. 15
 COUNTY OF SACRAMENTO, CA.

SITE PLAN	
DATE:	12/8/2020
SHEET	0.1

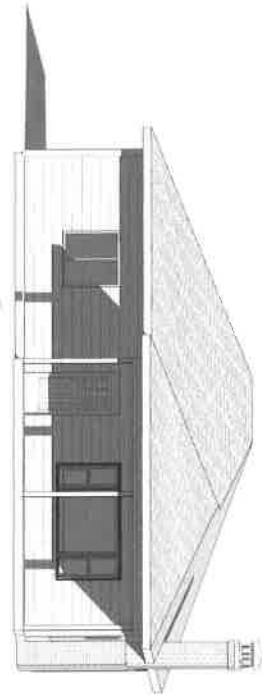

1 PERSPECTIVE
02

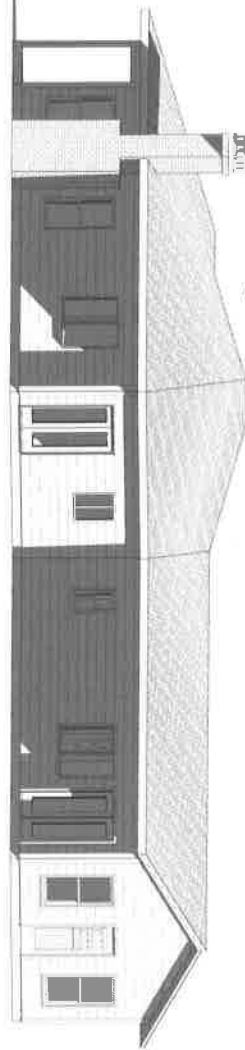

2 PERSPECTIVE 3
02

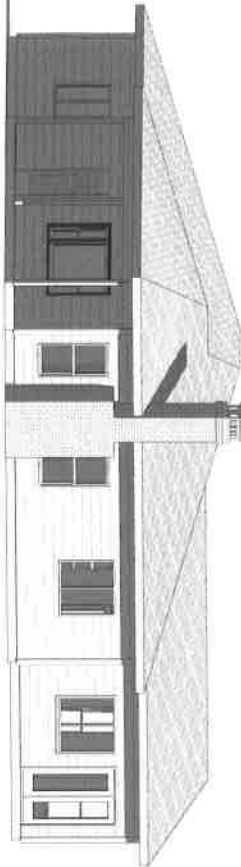

3 PERSPECTIVE 4
02

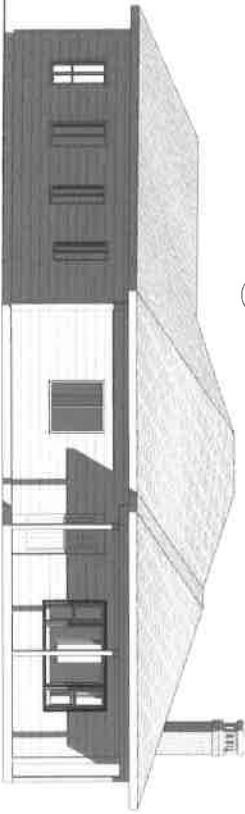

4 PERSPECTIVE 5
02



5 EXISTING RESIDENCE
02

SQUARE FOOTAGE CALLS:
EXISTING RESIDENCE: 377.00 SQ. FT.

RESERVED FOR CITY OF FOLSOM

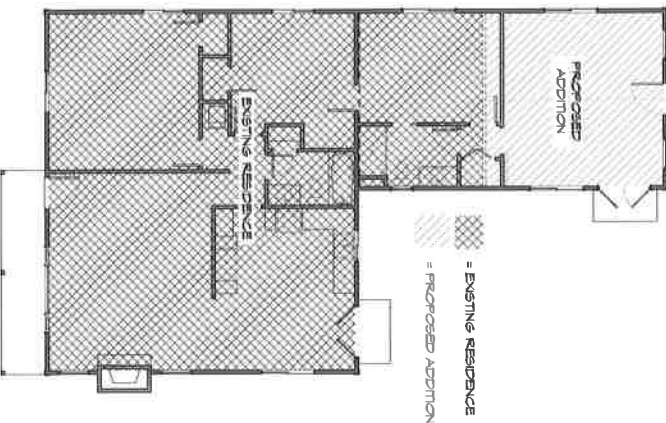

6 UNIT PLAN
02

SHEET
0.2

LYLE LINSCHED
3/20/21
EXTERIOR VIEWS

ADDITION TO AN EXISTING RESIDENCE
Project Name

ADDITION FOR:
MR. ERIC WINOKUR
(408) 921-4207
813 NATOMA ST.
FOLSOM, CA. 95630

Eric Winokur

THE CADD STATION
LYLE LINSCHED
PO BOX 1112
REDMOND, OR 97756
(541) 948-7605
caddsw@thecaddstation.com



1 FRONT ELEVATION
1/4" = 1'-0"

RESEVED FOR CITY OF FOLSOM

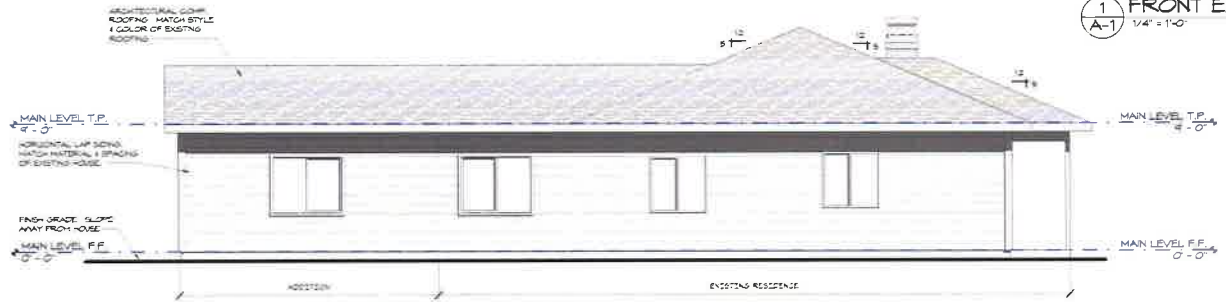

2 LEFT ELEVATION
1/4" = 1'-0"



3 RIGHT ELEVATION
1/4" = 1'-0"



4 REAR ELEVATION
1/4" = 1'-0"

THE CADD STATION
LYLE UNSCHIED
PO BOX 1112
REDMOND, OR 97053
503.754.6455
caddman@thecaddstation.com

ADDITION FOR:
MR. ERIC WINKUR
(408) 921-4207
813 NATOMA ST.
FOLSOM, CA 95630

Project Name
ADDITION TO
AN EXISTING
RESIDENCE

LYLE UNSCHIED
3/22/21
EXTERIOR
ELEVATIONS

SHEET
A-1

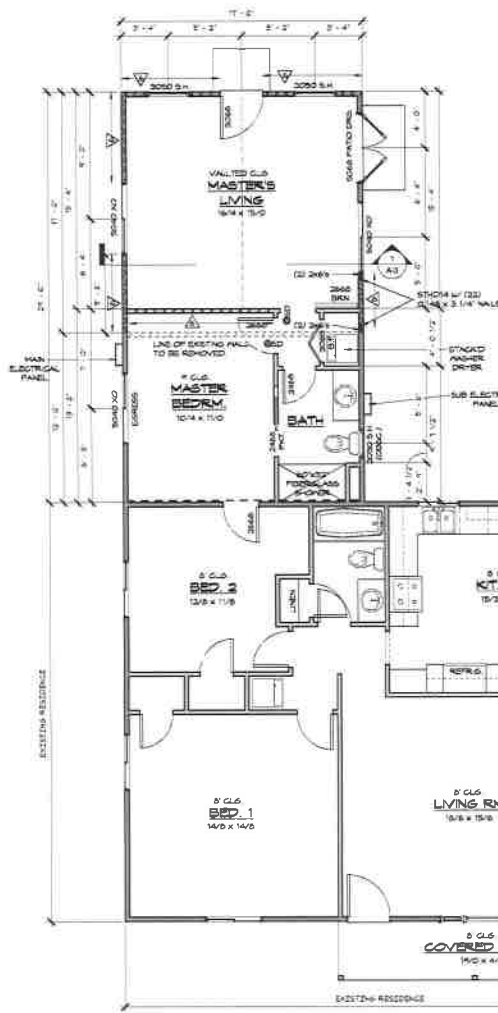

TYP. FLR. PLAN NOTES

1. EACH BEDROOM TO HAVE A MINIMUM WINDOW OPENING OF 5'5.0 FT. WITH A MIN. WIDTH OF 32" AND A SILL LESS THAN 44" OFF THE FLOOR.
2. ALL WINDOWS WITHIN 18" OF THE FLOOR AND WITHIN 12" OF ANY DOOR ARE TO HAVE TEMPERED GLAZING.
3. SKYLITES ARE TO BE GLAZED WITH TEMPERED GLASS ON OUTSIDE AND LAMINATED GLASS ON INSIDE (ALLES FLEXIGLASS). GLASS TO HAVE MINIMUM CLEAR SPAN OF 20". SKYLITE FRAME IS TO BE ATTACHED TO CURB WITH MINIMUM OF 4" ABOVE ROOF PLANE.
4. ALL TUB AND SHOWER ENCLOSURES ARE TO BE GLAZED WITH SAFETY GLAZING.
5. ALL EXTERIOR WINDOWS ARE TO BE DOUBLE GLAZED AND ALL EXTERIOR DOORS ARE TO BE SOLID CORE WITH WEATHERSTRIPPING. PROVIDE 1/2" DEADBOLT LOCKS ON ALL EXTERIOR DOORS AND LOCKING DEVICES ON ALL DOORS AND WINDOWS WITHIN 10' VERTICAL OF GRADE.
6. CONNECT ALL SMOKE DETECTORS (SEE PLAN FOR LOCATION) TO HOUSE ELECTRICAL SYSTEM AND INTERCONNECT EACH ONE SO THAT WHEN ANY ONE IS TRIPPED THEY WILL ALL SOUND.
7. PROVIDE COMBUSTION AIR VENTS (W/ SCREEN AND BACK DAMPER) FOR FIREPLACES, WOOD STOVES AND ANY APPLIANCES WITH AN OPEN FLAME.
8. BATHROOMS AND W/LLY ROOMS ARE TO BE VENTED TO THE OUTSIDE WITH A MINIMUM OF A 90 CFM FAN. RANGE HOODS ARE ALSO TO BE VENTED TO THE OUTSIDE.
9. STANDARD PLATE HEIGHT FOR WALLS TO BE MIN. 4" ABOVE SHEATHED FLOOR.
10. WINDOW HEAD HEIGHTS TO BE 1'-0" ABOVE SHEATHED FLOOR UNLESS NOTED OTHERWISE.
11. ALL HEATING ELEMENTS TO BE A MIN. OF 18" ABOVE FINISHED FLOOR.

SQUARE FOOTAGE CALC.

EXISTING HOUSE	1,211 SQ. FT.
ADDITION	281 SQ. FT.
TOTAL LIVING AREA	1,506 SQ. FT.

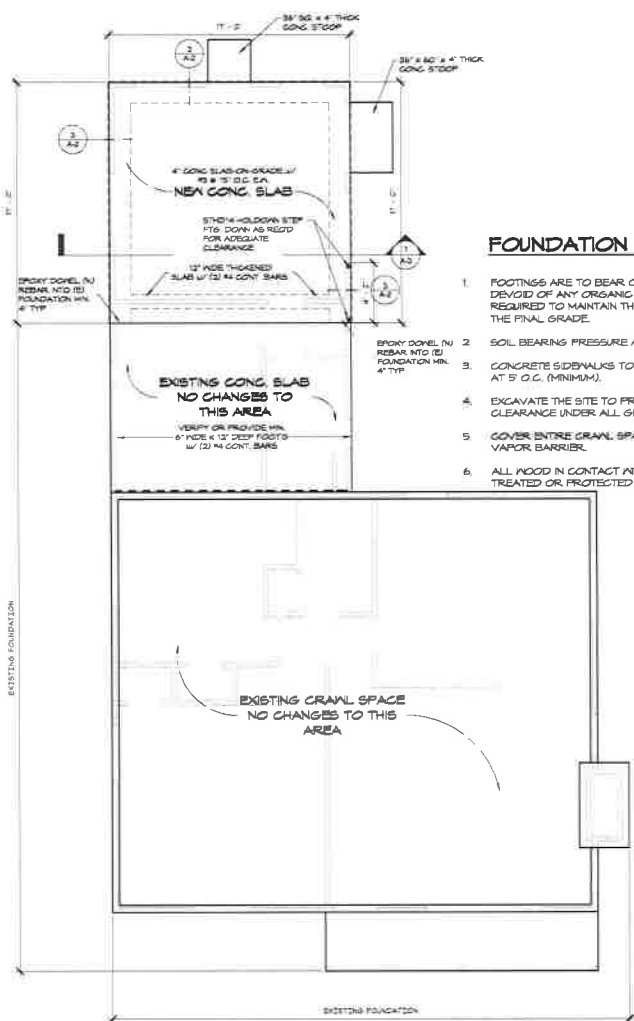

FOUNDATION NOTES

1. FOOTINGS ARE TO BEAR ON UNDISTURBED LEVEL SOIL. DEVICED OF ANY ORGANIC MATERIAL AND STEPPED AS REQUIRED TO MAINTAIN THE REQUIRED DEPTH BELOW THE FINAL GRADE.
2. SOIL BEARING PRESSURE ASSUMED TO BE 1500 P.S.F.
3. CONCRETE SIDEWALKS TO HAVE 3/4" TOOLED JOINTS AT 5' O.C. (MINIMUM).
4. EXCAVATE THE SITE TO PROVIDE A MINIMUM OF 18" CLEARANCE UNDER ALL GIRDERS.
5. COVER ENTIRE CRAWL SPACE WITH 6 MIL. "BLACK" VAPOR BARRIER.
6. ALL WOOD IN CONTACT WITH CONCRETE TO BE PRESSURE TREATED OR PROTECTED WITH 55# ROLL ROOFING.

NOTES:

▽ INDICATES SHEARWALL. REFER TO SHEARWALL NOTES AND FASTENING REQUIREMENTS BELOW.

1. PROVIDE MIN. 1/8" O.S.B. ONE SIDE OF TYPE # SHEARWALL W/ #8 @ 6" O.C. EDGE NAILING AND #6 @ 12" O.C. FIELD NAILING. SHEATHING MAY BE INSTALLED VERTICALLY OR HORIZONTALLY. USE ONLY COMMON OR BOX WALLS (GALVANIZED) FOR ALL PANELS. AND SILL PLATE NAILING (GALVANIZED) WALLS SHALL BE HOT-DIPPED OR TUMBLED. FASTEN TO FOUNDATION W/ 5/8" DIA. X 10" ANCHOR BOLTS @ 40" C.C. THERE SHALL BE A MINIMUM OF TWO ANCHOR BOLTS PER PIECE OF SILL PLATE WITH ONE BOLT LOCATED NOT MORE THAN 12" OR LESS THAN 4" FROM EACH END.
2. ALL FRAMED SHEAR WALL SHALL BE BLOCKED AT ALL PANEL EDGES.
3. 3/8" X 20" 20' THICK PLATE ANCHORS ARE REQUIRED @ ANCHOR BOLTS.

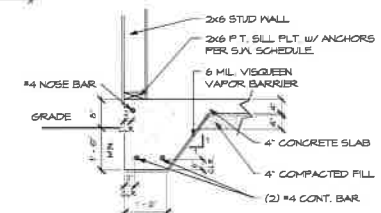

(3) SLAB ON GRADE DETAIL
1/4" = 1'-0"

RESERVED FOR CITY OF FOLSOM

THE CADD STATION
LYLE LINSCHIED
FO BOX 1112
REDMOND, OR 97056
caddinfo@thecaddstation.com

Eric Winkur

ADDITION FOR:
MR. ERIC WINKUR
(408) 921-4207
813 NATOMA ST.
FOLSOM, CA 95630

Project Name
ADDITION TO AN EXISTING RESIDENCE

LYLE LINSCHIED
3/22/21
FOUNDATION / FLOOR PLAN

SHEET
A-2

Attachment 6

Site Photos



Attachment 7
Staff PowerPoint Presentation

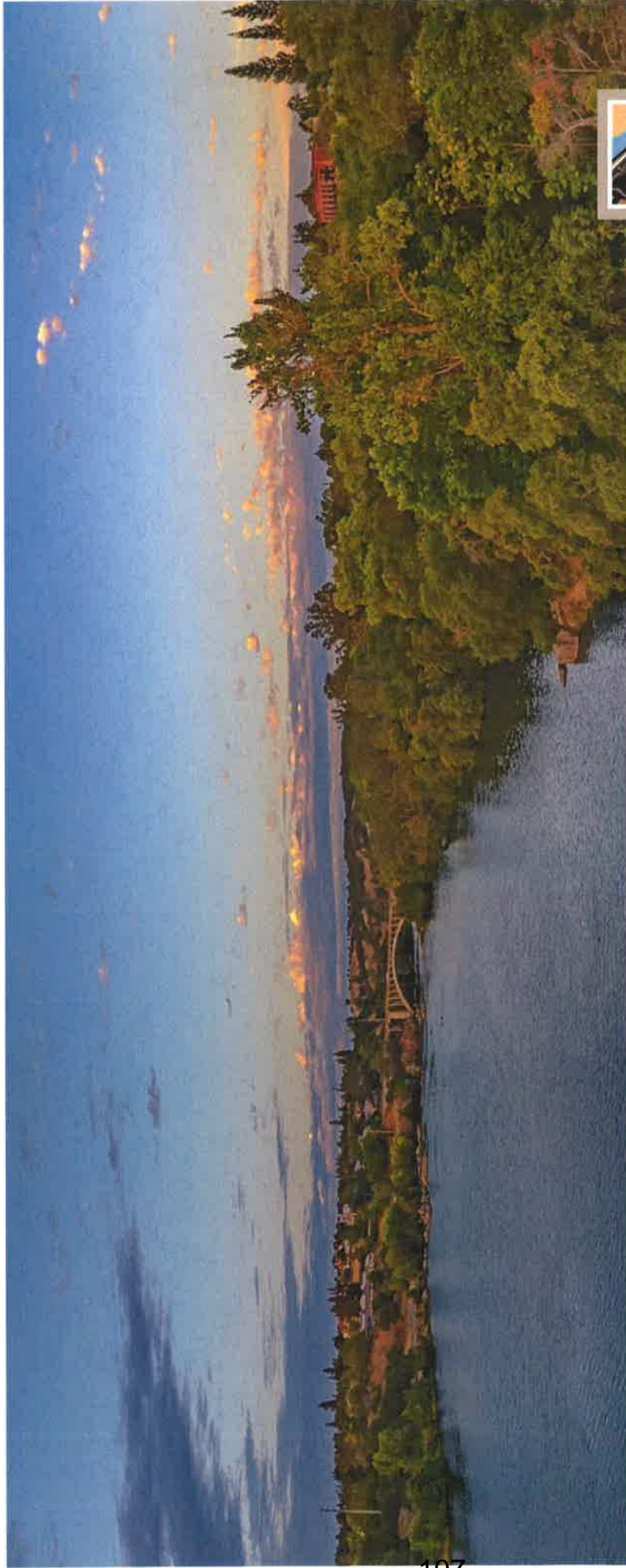

PN 21-058: 813 Natoma Street Addition Design Review



CITY OF
FOLSOM

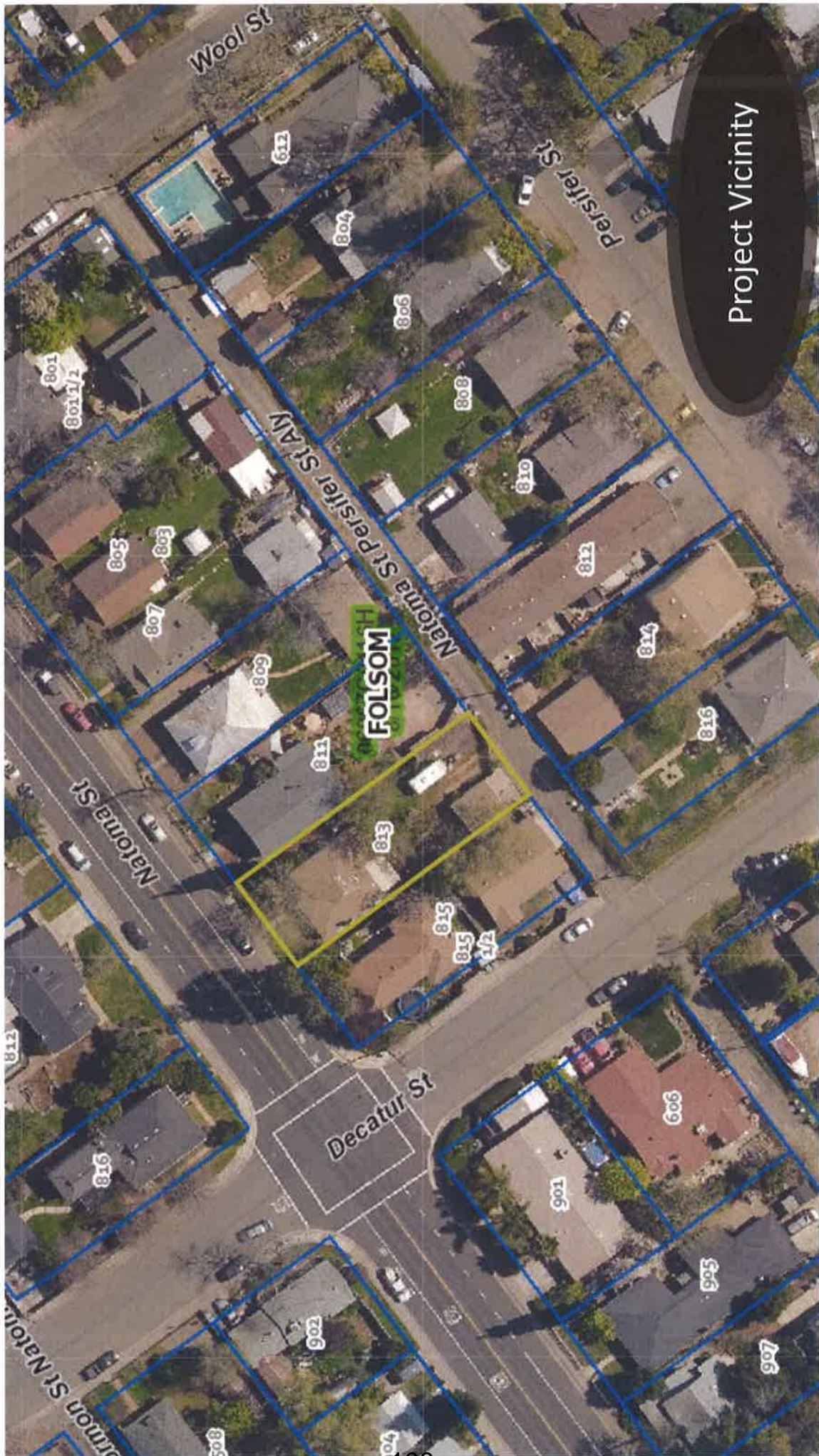

Site Photos



CITY OF
FOLSOM



Site Plan



CITY OF
FOLSOM

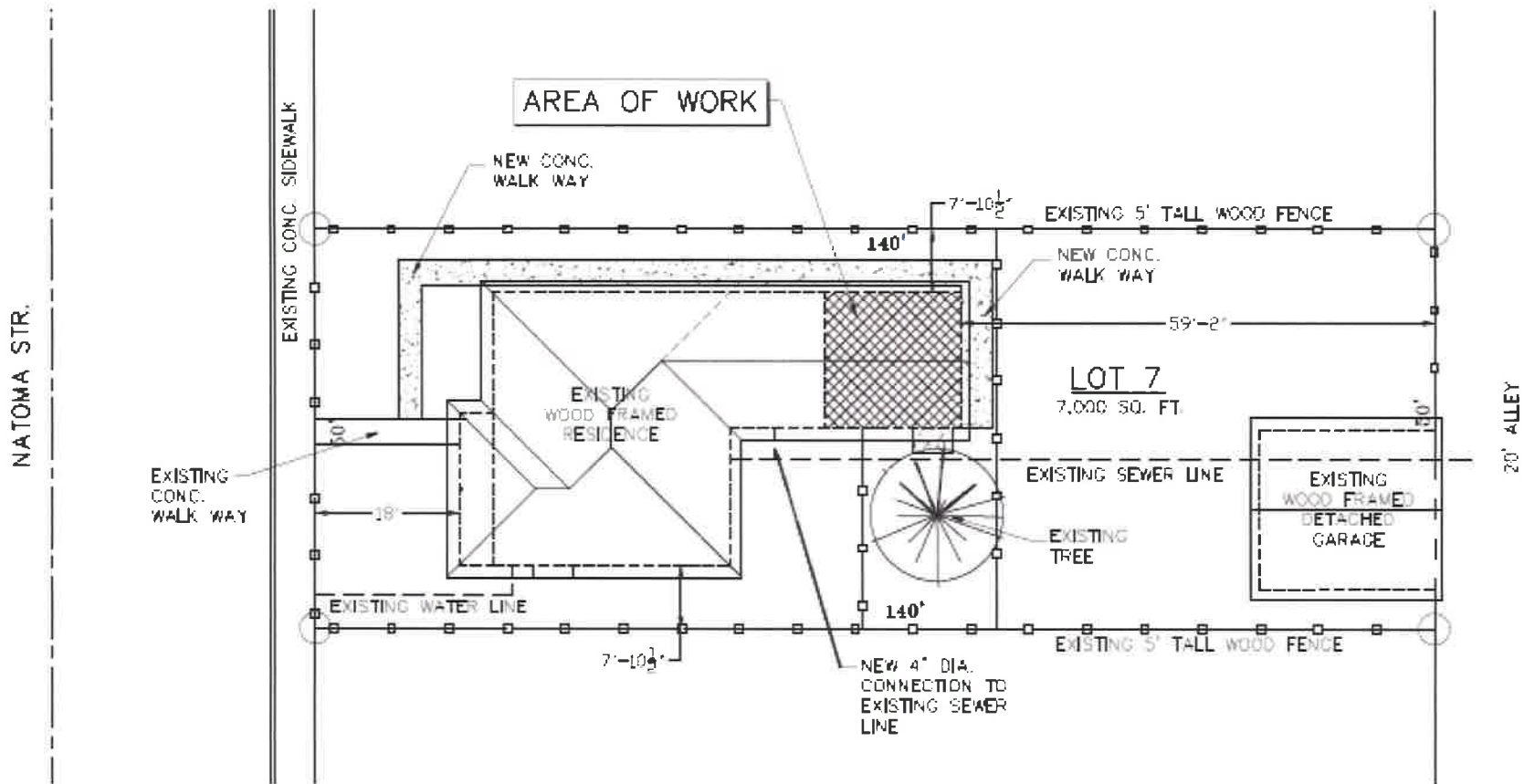

Elevations



CITY OF
FOLSOM



Staff Recommendation



CITY OF
FOLSOM

Staff recommends approval of PN 21-058 for Design Review for a 291-square-foot addition to an existing single-family residence located at 813 Natoma Street.